

Manager

User Guide

Document version: v 11
Software Version: v 4.0

CONTENTS





| | |
|--|-----------|
| HOW TO READ THIS DOCUMENT? | 4 |
| COPYRIGHT AND TRADEMARKS | 4 |
| OVERVIEW | 5 |
| <i>The Aviwest video contribution ecosystem</i> | 5 |
| <i>Main Functions</i> | 5 |
| <i>Optional Functions</i> | 6 |
| <i>Interface Overview</i> | 6 |
| GETTING STARTED | 15 |
| <i>Connecting to the Manager Interface</i> | 15 |
| <i>Modifying the Administrator Password</i> | 16 |
| SETTING UP AN ECOSYSTEM | 17 |
| <i>Creating Groups</i> | 18 |
| <i>Adding Transmitters</i> | 18 |
| <i>Adding Receivers</i> | 19 |
| MANAGING USER ACCOUNTS | 20 |
| <i>Creating User Accounts</i> | 20 |
| <i>Modifying a User Account</i> | 22 |
| <i>Deleting a User Account</i> | 22 |
| <i>Checking a User Profile</i> | 23 |
| MANAGING GROUPS | 24 |
| <i>Changing a Field Unit's Group</i> | 24 |
| <i>Changing the Receiver's Group</i> | 25 |
| <i>Changing the group of a Receiver's output(s)</i> | 25 |
| <i>Modifying Receiver Priority</i> | 26 |
| <i>Modifying the Group Credentials</i> | 27 |
| <i>Deleting a Group</i> | 27 |
| MANAGING VIDEO ROUTES | 28 |
| <i>Booking</i> | 28 |
| <i>Assigning Resources Manually</i> | 33 |
| <i>Understanding the default video routes within a group</i> | 36 |
| <i>Enabling the Straight Mode for SDI Outputs</i> | 38 |
| SETTING A VIDEO RETURN FOR A FIELD UNIT | 40 |
| SETTING A DISTRIBUTION POINT | 41 |
| MANAGING PRODUCTS | 44 |
| <i>Enabling / Disabling Products</i> | 44 |
| <i>Deleting Products</i> | 45 |
| <i>Modifying the Connection Settings of a Receiver</i> | 46 |
| MANAGING FIELD UNITS | 47 |
| <i>Updating Field Units' Firmware</i> | 47 |
| <i>Updating Field Units' Configuration</i> | 49 |
| <i>Locking the Server Profile on a Field Unit</i> | 50 |

| | |
|--|-----------|
| CONTROLLING FIELD UNITS REMOTELY | 51 |
| <i>Accessing the Remote User Interface of a Field Unit</i> | 51 |
| <i>Accessing the Web Configurator of a DMNG PRO 1x0</i> | 52 |
| <i>Starting a Live.....</i> | 53 |
| <i>Managing Files</i> | 53 |
| MANAGING A RECEIVER | 55 |
| <i>Disconnecting a field unit from the receiver</i> | 55 |
| <i>Managing outputs</i> | 55 |
| MONITORING AN ECOSYSTEM | 57 |
| <i>Using filters</i> | 57 |
| <i>Monitoring the Field Units.....</i> | 57 |
| <i>Monitoring the Receivers</i> | 61 |
| <i>Geolocating Field Units</i> | 64 |
| MANAGING DATA USAGE | 65 |
| <i>Statistics on Field Units and Cellular Data Usage</i> | 65 |
| <i>Setting the Data Amount on a SIM Card.....</i> | 66 |
| <i>Monitoring the Use of Field Units</i> | 67 |
| <i>Monitoring the Cellular Data Usage.....</i> | 68 |
| INTERCOM | 71 |
| <i>Initializing a conference.....</i> | 71 |
| <i>Joining a conference.....</i> | 72 |
| <i>Calling a field unit.....</i> | 73 |
| <i>Calling several field units.....</i> | 74 |
| <i>Calling all field units of a group</i> | 75 |
| MANAGING METADATA FOR STORY CENTRIC WORFLOW..... | 76 |
| <i>Run-Down or Planning Mode</i> | 77 |
| <i>XML and JSON File Formats for Run Down Mode</i> | 78 |
| <i>XML File Format for Planning Mode.....</i> | 79 |
| MANAGING SERVER REDUNDANCY | 82 |
| <i>Configuring redundancy.....</i> | 83 |
| <i>Monitoring redundancy.....</i> | 86 |
| MAINTAINING THE MANAGER | 89 |
| <i>Restarting</i> | 89 |
| <i>Updating</i> | 89 |
| <i>Exporting the Connection Profile.....</i> | 90 |
| <i>Exporting the Database.....</i> | 90 |
| <i>Importing the Database</i> | 90 |
| <i>Account Locking Policy.....</i> | 91 |
| <i>Unlocking the Web Page.....</i> | 91 |
| TROUBLESHOOTING | 92 |
| <i>Viewing the Logs.....</i> | 92 |
| <i>Getting a Report File.....</i> | 92 |
| <i>Connection Errors.....</i> | 93 |
| CONTACT US | 94 |

How to Read this Document?

The document provides instructions to operate Manager.

To facilitate the navigation through this User Guide, we adopt the following text styles and symbols:

| | |
|---|--|
| UI term | Terms highlighted in bold are user interface terms. |
| <i>Variable</i> | Data that can vary, such as default values, are in italic. |
|  | Actions or elements required before doing an operation. |
|  | Important information, reminders, recommendations, or tips. |
|  | Precautions to avoid any damage to the equipment or environment. |
|  | Precautions to avoid any physical injury. |

Important notice: The content of this guide may be modified without notice. Please login to your Extranet on <http://www.aviwest.com> to make sure that you have the latest version of this guide.

Copyright and Trademarks

This User Guide and its content are the property of AVIWEST. It is forbidden to copy, disclose, or reproduce either the whole document or any part without AVIWEST's prior written agreement.

Overview

The Manager is a web-based application that allows monitoring and managing a video contribution ecosystem.

The Aviwest video contribution ecosystem

The Aviwest ecosystem is a video contribution system for streaming live and recorded video content over bonded unmanaged IP networks.

It is composed of field units and receivers allowing live video content to be delivered to Master Control Rooms.

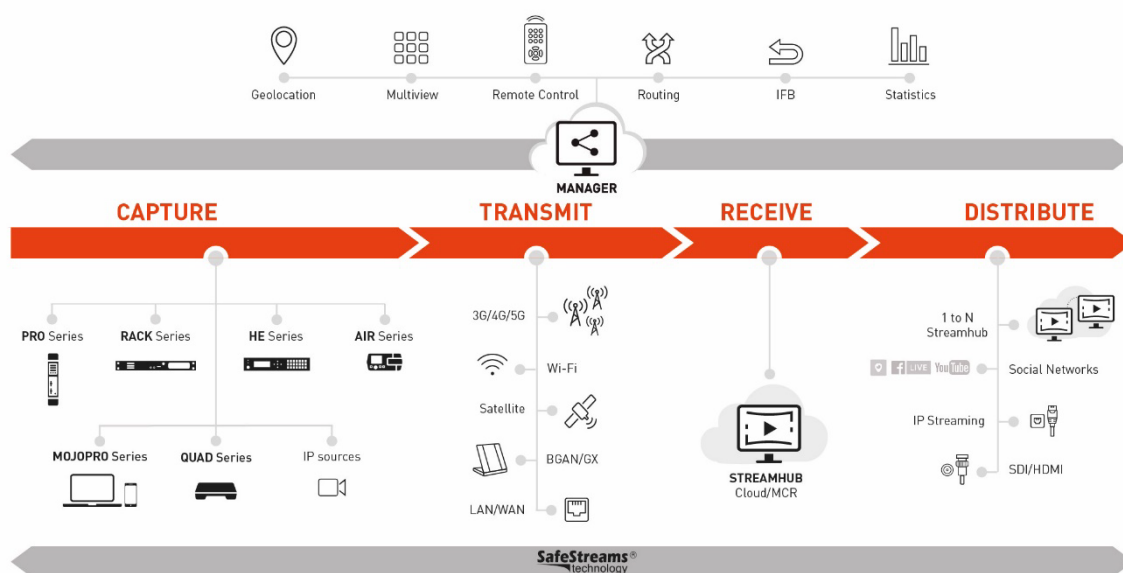

Main Functions

Through its main five tabs, **Grid, Maintenance, Stats, Map and Logs**, the Manager interface offers the following main functions:

- Managing video routes
- Managing Groups and Users
- Monitoring an entire Ecosystem
- Configuring and Updating Field Units Remotely
- Controlling Products Remotely
- Consulting information about events, error and warning messages

Optional Functions

- SIP Intercom
- Full Statistics function (monitoring cellular data and field units usage)
- Map view

Interface Overview

The Manager interface is composed of several items.

The screenshot shows the AVIWEST Manager interface with several components labeled:

- Menu Bar:** Located at the top, containing 'admin', 'Settings', 'Booking', and 'Help'.
- Tab Bar:** Located below the menu bar, containing 'Grid', 'Intercom', 'Maintenance', 'Stats', 'Map', 'Logs', and a notification badge for '12'.
- Search Bar:** A search input field located below the menu bar.
- Conference Panel:** A panel showing a video call with 'admin' and 'PRO3_MNA'.
- Field Unit Panel:** A panel showing a video call with 'PRO_ALE' and 'adupont@aviwe...'.
- Receiver Panel:** A panel showing a list of receivers, including 'PRO3-P35-FPR', 'PRO3_MNA', and others.
- Filter Panel:** A panel showing filter options for 'PRODUCTS', 'STATUS', 'BOOKING', and 'GROUPS'.
- About Section:** A panel showing system information such as 'Online receivers', 'Online field units', 'Manager users', 'SIP', 'Public IP', 'Local IP 1', 'Firmware version', 'Hardware ID', and 'Running mode'.

The main interface area displays 'SOURCES' (1-2/2), 'RECEIVERS' (1-6/6), and 'OUTPUTS' (1-5/5). The 'RECEIVERS' section includes a table with columns for receiver ID, status, and a grid of buttons. The 'OUTPUTS' section shows a vertical list of video feeds.

Menu Bar

The menu bar is different whether you are logged in as “**admin**” or “**user**”.

When logged in as User

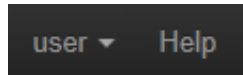

- The **user** menu allows to logout and see the profile details (permissions and groups).
- The **Help** menu redirects to the customer portal.

When logged in as Administrator



- From the **admin** menu you can:
 - Change the administrator password
 - Logout
 - Access to the License details, and applying a new license
 - Maintain the Manager software
 - Restarting
 - Updating
 - Getting a report
 - Importing and exporting the database
 - Importing the cell Id database.
 - Exporting the connection profile
 - Access to the API REST documentation
- From the **Settings** menu you have access to:
 - **General** management (logging security policy, connection settings, SIP intercom, story centric workflow, REST API, Server Redundancy settings, Video Return enabling/disabling)
 - **Group** management
 - **User** Account management
 - **Role** management
 - **Receiver** management
 - **Distribution Point** management
 - **Field Unit** management (Config and Firmware uploading)
- From the **Booking** menu you manage live reservations within each group.
- The **Help** button redirects to the customer portal.

Tab bar

From these tabs you can have access to different views of the managed ecosystem and various functionalities.

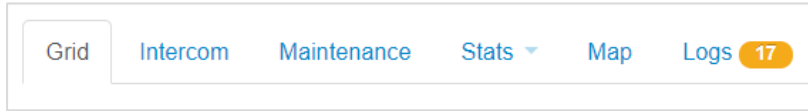

Note:

According to the access rights given by the Administrator, a user may have restricted access and may not see all tabs.

Grid Tab

Under the **Grid** tab, some thumbnails represent key elements:

Field units and their status (online / offline / live...)

Receivers identified within the managed ecosystem indicating the status of their inputs

The outputs are split into three tabs according to their type: SDI, NDI or IP outputs

Intercom Tab

Under the Intercom tab you can start a conference call with field units.

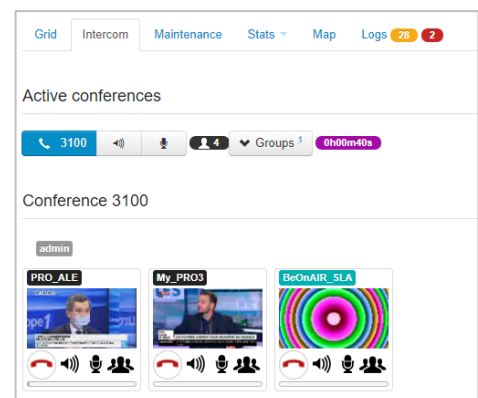





Maintenance Tab

The **Maintenance** tab gives the list of all products included in an ecosystem.

You can use filters on the left panel (PRODUCTS, STATUS, BOOKING, GROUPS) and sort displayed products by clicking on the headers.

To easily identify the products shown on the **Maintenance** tab, a different color is used for each product type:

| | |
|---|----------------|
|  | AIR Field Unit |
|  | PRO Field Unit |
|  | HE4000/ RACK |
|  | MOJOPRO / APP |
|  | Receiver |

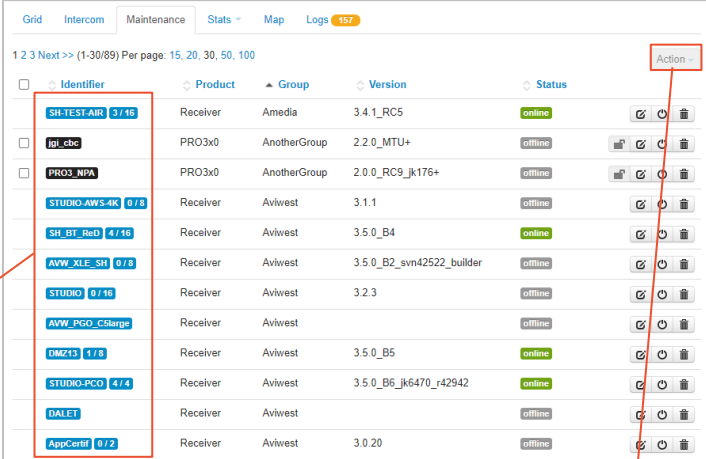

| Identifier | Product | Group | Version | Status | Action |
|---------------------|----------|--------------|---------------------------|---------|----------|
| SH-TEST-AIR 3 / 16 | Receiver | Amedia | 3.4.1_RC5 | online | [Action] |
| lpl_cbc | PRO3x0 | AnotherGroup | 2.2.0_MTU+ | offline | [Action] |
| PRO3_NPA | PRO3x0 | AnotherGroup | 2.0.0_RC9_jk176+ | offline | [Action] |
| STUDIO-AWS-4K 0 / 8 | Receiver | Aviwest | 3.1.1 | offline | [Action] |
| SH_BT_Red 4 / 16 | Receiver | Aviwest | 3.5.0_B4 | online | [Action] |
| AWW_XLE-SH 0 / 8 | Receiver | Aviwest | 3.5.0_B2_svn42522_builder | offline | [Action] |
| STUDIO 0 / 16 | Receiver | Aviwest | 3.2.3 | offline | [Action] |
| AWW_PGO_CStarge | Receiver | Aviwest | | offline | [Action] |
| DMZ13 1 / 8 | Receiver | Aviwest | 3.5.0_B5 | online | [Action] |
| STUDIO-PCO 4 / 4 | Receiver | Aviwest | 3.5.0_B6_jk6470_r42942 | online | [Action] |
| DALET | Receiver | Aviwest | | offline | [Action] |
| AppCertif 0 / 2 | Receiver | Aviwest | 3.0.20 | offline | [Action] |

From the **Action** menu, you can:

- Update a field unit firmware, and cancel the update
- Import a configuration file or a SIM configuration onto field units
- Start a conference call
- Delete one or several field units

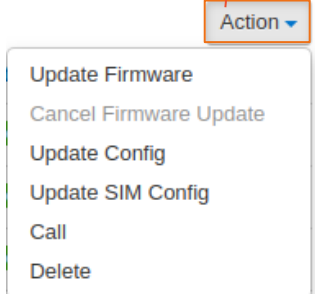

| |
|------------------------|
| Action |
| Update Firmware |
| Cancel Firmware Update |
| Update Config |
| Update SIM Config |
| Call |
| Delete |

Note:

The **Action** menu is accessible once you ticked the box(es) of the field unit(s) for which you want to do an action.

Stats Tab

Under the **Stats** tab, you can:

- Set the data amount on SIM cards
- Delete SIM cards
- Get statistics about field units and cellular data usage

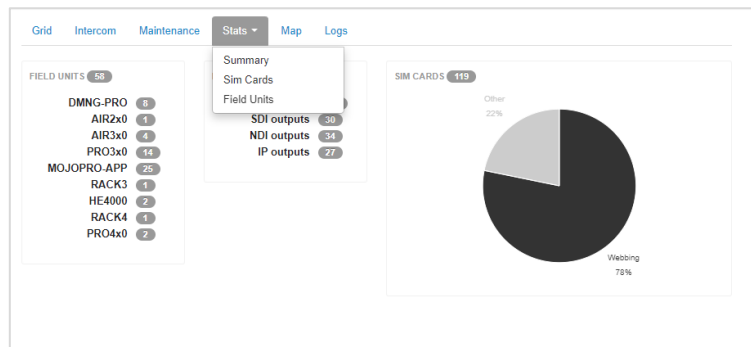

Map Tab

The main purpose of the **Map** tab is to locate and monitor an entire ecosystem at a glance via a map.

The **Map** tab shows all field units with a known position (currently connected to the Manager interface or not).

You can use filters on the left panel (PRODUCTS, STATUS, BOOKING, GROUPS).

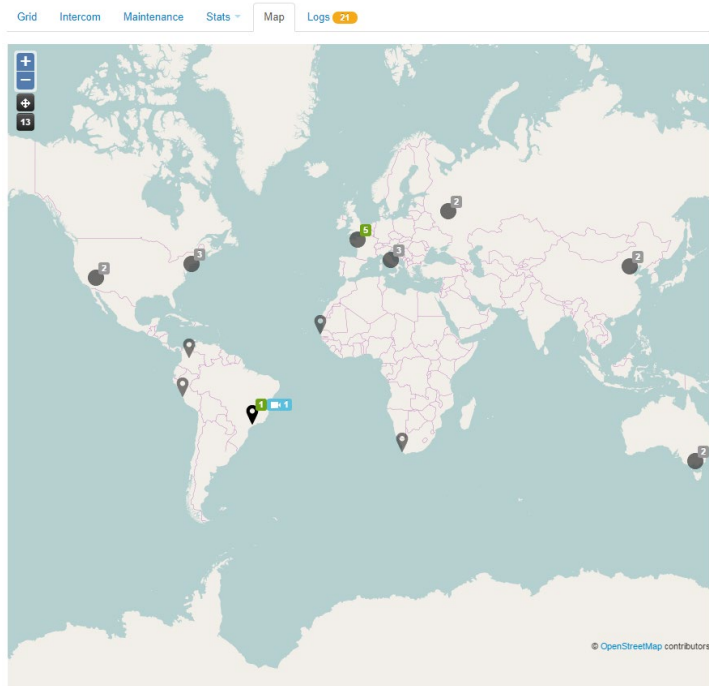

Color codes are used to indicate the status of field units:

| | |
|--|-----------------------|
| | Offline Unit |
| | Several offline units |
| | Online unit |
| | Action in progress |

Logs Tab

The **Logs** page lists information, error and warning messages.

By default, the page is automatically refreshed as soon as a new event occurs.

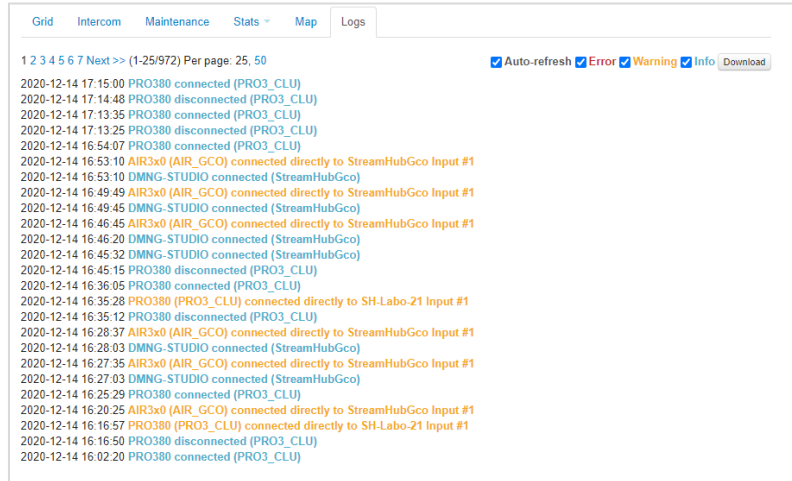

If needed, you can untick the **Auto-refresh** checkbox so that the **Logs** page is no longer refreshed. If so, new events are no longer displayed until ticking the checkbox again.

You can use the checkboxes **Error**, **Warning** and **Info** to filter the events according to their type.

Click the **Download** button to download the logs.

The **Logs** page is cleared after restarting the Manager software and after rebooting the server. However, the downloadable log file always includes the events occurred over the past 7 days.

Note:

The log time refers to the Manager local time.

Conference panel

Once a conference call has started, the conference panel is displayed.

From this panel, you can:

- leave the conference
- mute / unmute speakers and microphones
- check the number of attendees and the duration

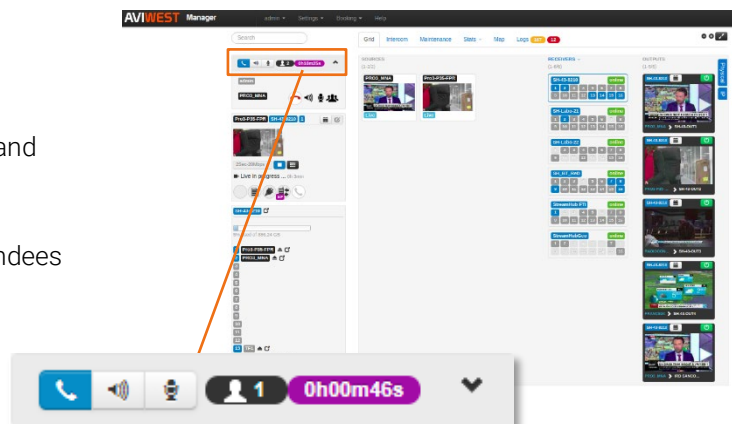

Field Unit panel

The field unit panel provides:

- information and indicators about the field unit
- remote control functions
- access to the Web configurator

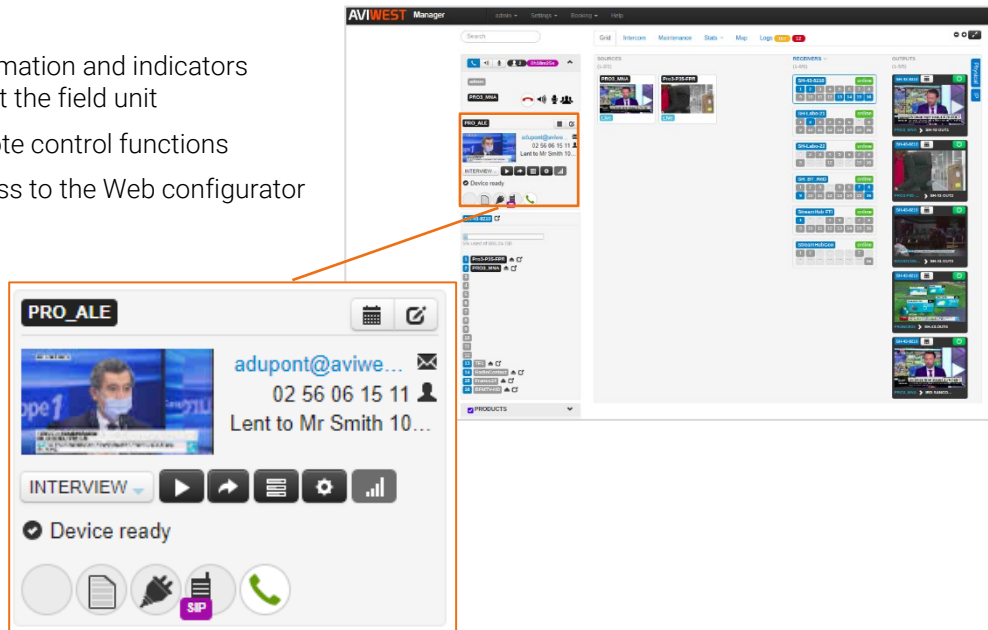

Filters panel

You can select filters to display products according to your needs.

You can filter by:

- PRODUCTS
- STATUS
- BOOKING
- GROUPS

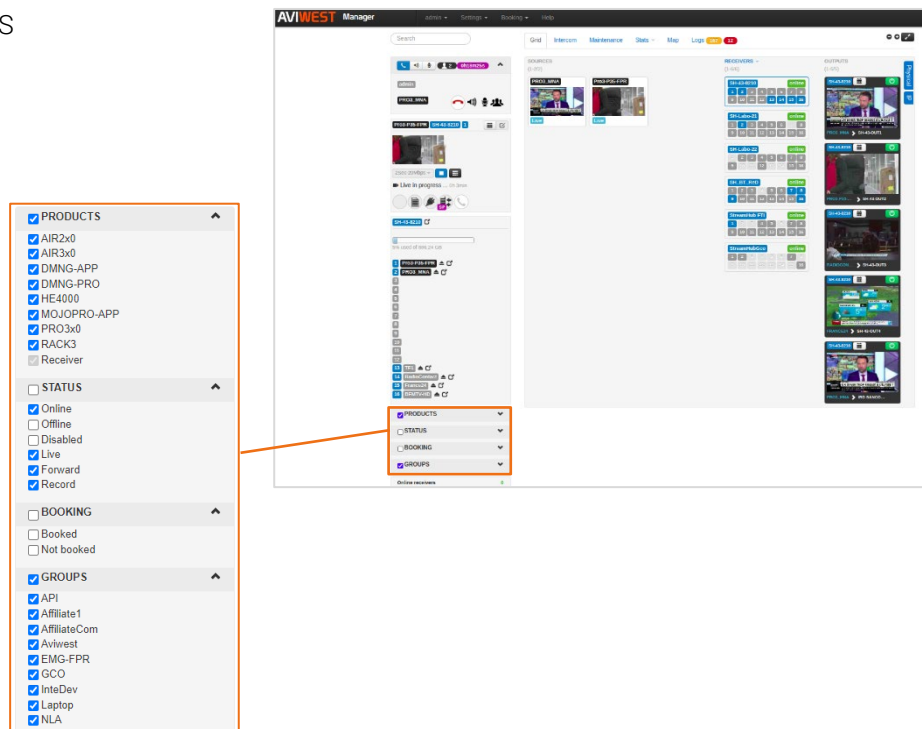

About Section

The About section provides general information:

| | |
|---------------------------|--------------------------|
| Online receivers | 3 |
| Online field units | 1 |
| Manager users | 1 |
| SIP | registered |
| Public IP | 88.87.188.188 |
| Local IP 1 | 10.80.2.86 |
| Firmware version | 3.0.0 |
| Hardware ID | 74:d4:35:30:65:b9 |
| Running mode | Standalone |

| | |
|--------------------|--|
| Online receivers | The number of receivers currently connected to Manager (i.e. which status is online) |
| Online field units | The number of field units currently connected to Manager |
| Manager users | The number of people (admin and users) currently logged in to the Manager |
| SIP | Status of SIP registration |
| Public IP | Manager Public IP address |
| Local IP | Manager local IP addresses |
| Firmware version | Manager firmware version |
| Hardware ID | Manager hardware identifier |
| Running Mode | Running mode of the Server (Standalone / Master / Backup) |

Screen adjustment

To get more comfortable, you can adapt the screen display:

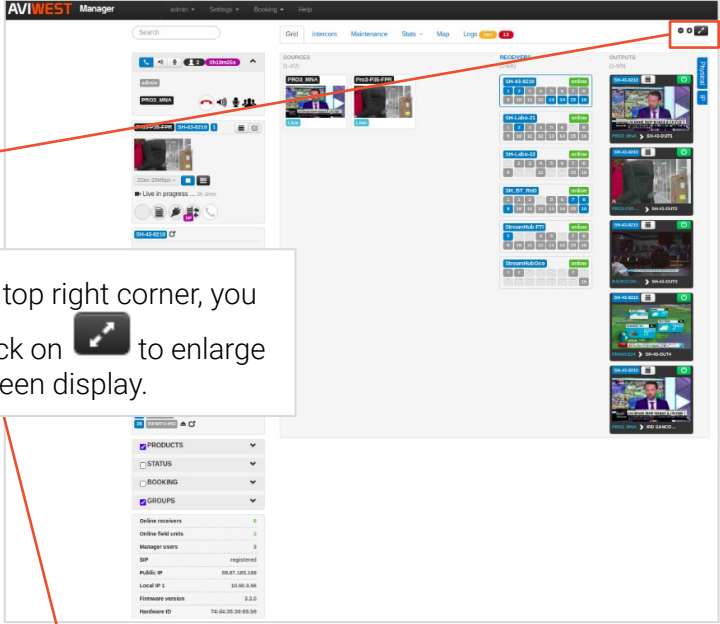

The screenshot shows the AVIWEST Manager interface in a grid view. A red box highlights the top right corner of the interface, containing three icons: a minus sign, a plus sign, and a diagonal arrow pointing up and to the right. A callout box points to these icons with the text: "On the top right corner, you can click on [diagonal arrow icon] to enlarge the screen display." Another callout box points to the plus and minus icons with the text: "You can click on [plus icon] or [minus icon] to adapt the number of graphic elements in the grid view." The interface displays various video feeds and system status information.

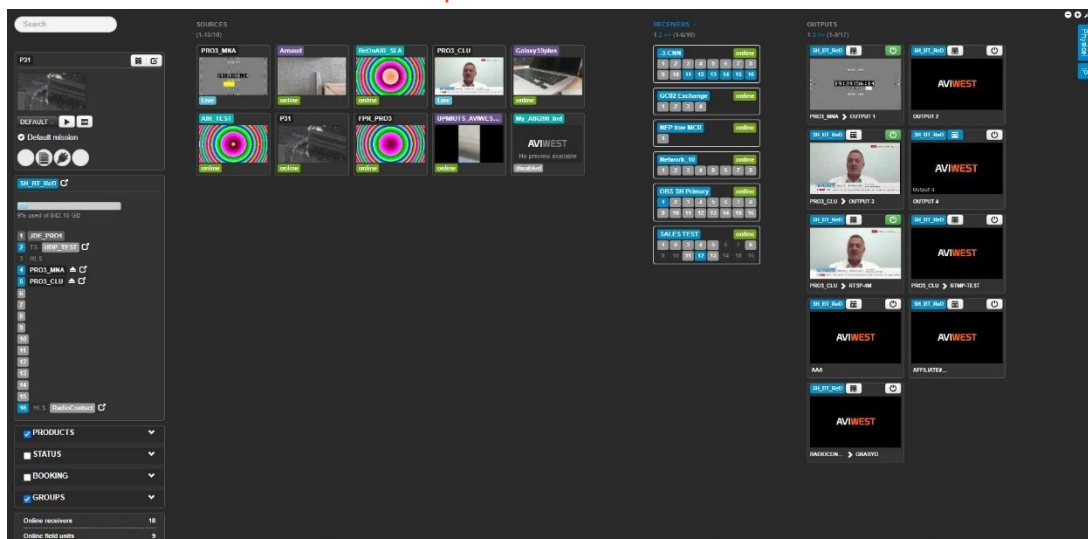

You can click on **+** or **-** to adapt the number of graphic elements in the grid view.

On the top right corner, you can click on **↗** to enlarge the screen display.



Getting Started

When using the Manager for the first time, and to ensure that it operates properly, please make sure that:

-  The server is installed in accordance with the instructions in the Installation guide.
-  The network interfaces of the server are properly configured according to your network architecture.
-  The network is properly configured: the router, firewall or proxy server to which is connected the Manager server allows traffic over TCP and UDP ports.

Connecting to the Manager Interface

1. Open a web browser on any computer connected to the Internet.

We recommend using Google Chrome or Firefox, and using https connection:

https:// followed by the Manager's public IP address.

For instance, if your Manager's public IP address is *109.190.1.25*, you have to type "https://109.190.1.25".

-  When using an http connection, type "http://" followed by the Manager's public IP address and ":8890".
For instance, if your Manager's public IP address is *109.190.1.25*, you have to type "http://109.190.1.25:8890".

2. Log in as Administrator with the following default settings:

Login: admin

Password: password

The interface opens.

We strongly recommend that the Administrator configures the general settings before using it for the first time, and especially the default password to log in to the interface.

Refer to the [Account Locking Policy](#) chapter to modify and or disable these settings.

Modifying the Administrator Password

We strongly advise you to modify the password to log in to the Manager as administrator.

1. In the menu bar, click on **admin**.
2. Click on **Password**.
3. Enter the current password in the **Password** field.
4. Enter the new password in the **New password** field.

The password must contain at least 8 characters and at least 3-character types (lower case, upper case, digit and/or special characters).

5. Confirm the new password in the **Confirm password** field.

The **Save** button is available only if the new password is successfully confirmed.

6. Click the **Save** button.

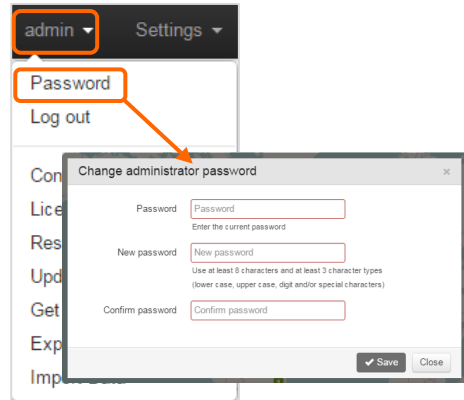

Setting up an Ecosystem

Preparing the Ecosystem means creating groups and adding receivers. You have to decide how to organize your ecosystem according to your needs. For instance, you can divide your fleet into groups based on:

- Geographical areas
- Types of field unit
- Custom

Among many other possibilities, it can be useful to create a group for temporary products in the ecosystem (for instance if you are used to working with freelance journalists who have their own field unit or if you rent field units for a special event).

The example below shows an ecosystem, divided into 3 groups:

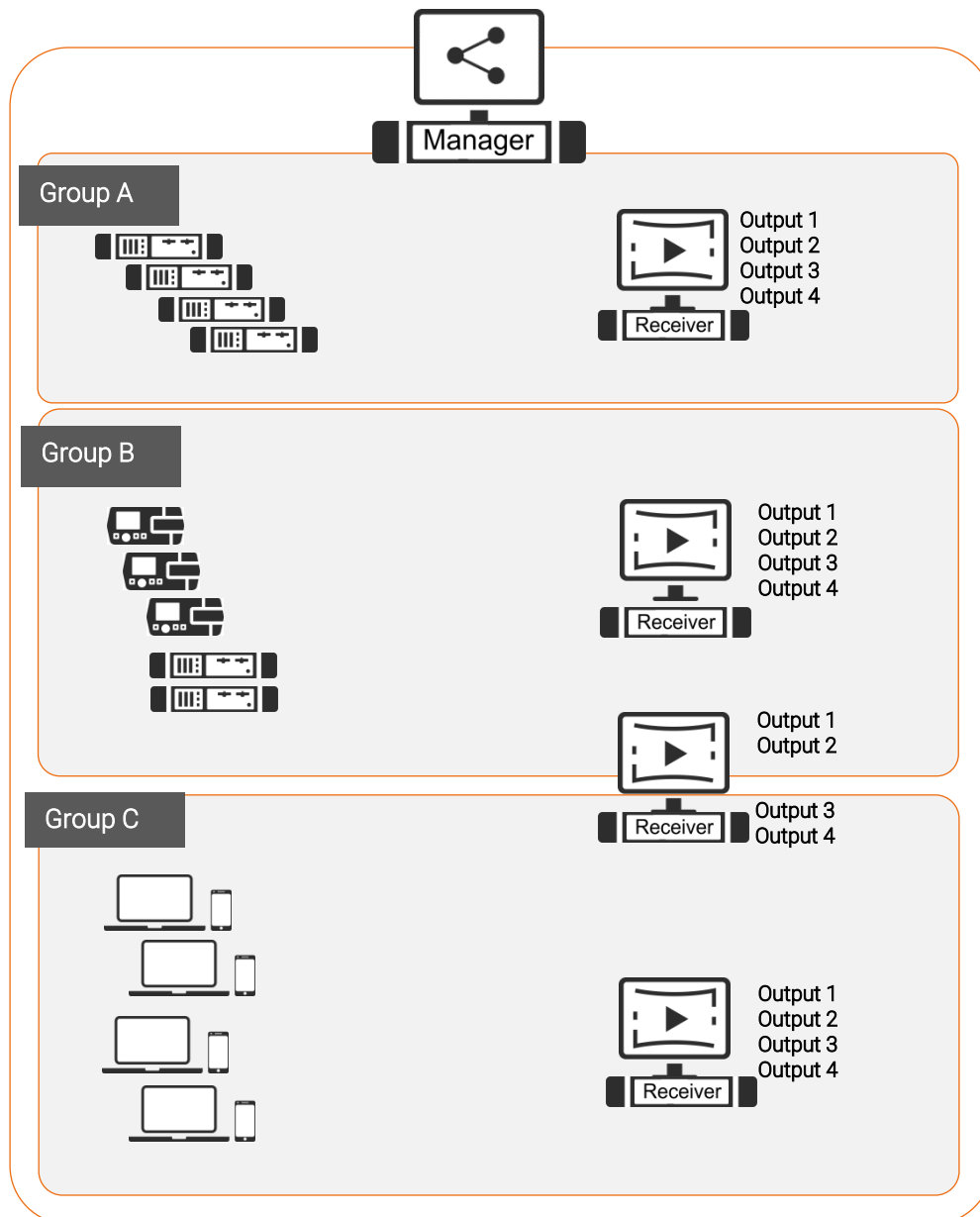

Creating Groups

Groups are fundamentals to monitor and control an ecosystem through the Manager.

A group includes:

- products (field units and receivers)
- receivers' outputs



Note:

A default group called "Aviwest" has the following credentials:

- Username: username
- Password: password

Only the administrator can create groups.
This default group cannot be deleted.

1. In the menu bar, click on **Settings**.
2. In the **Groups** section, click on **New**.
3. Enter a **Name** for the new group.
The name must include 3 to 20 characters, letters and digits (special characters are not allowed except underscore and hyphen).
4. Enter a **Username** and a **Password**.
The username and password must include 6 to 20 characters, letters and digits (space and special characters are not allowed except underscore).
Use a unique name and username for each group.
5. Click the **Save** button.

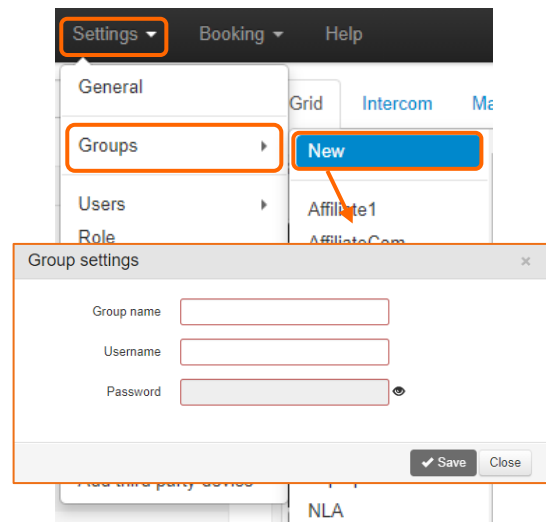

Note:

Once a group is created, receivers can be assigned to it, when adding them to the ecosystem (see chapter [Adding Receivers](#)).

Adding Transmitters

Adding transmitters means registering them into the Manager's database.

A transmitter is added automatically to the Manager after a successful connection.

From the transmitter's interface, you should set Manager as the Destination profile, with credentials matching one of Manager's groups.

Please refer to transmitters' respective User Manuals in chapters « [Adding and Configuring a Destination Profile](#) ».

Adding Receivers

Adding receivers means registering them into the Manager's product database.

Only the administrator can add receivers.

1. In the menu bar, click on **Settings**.

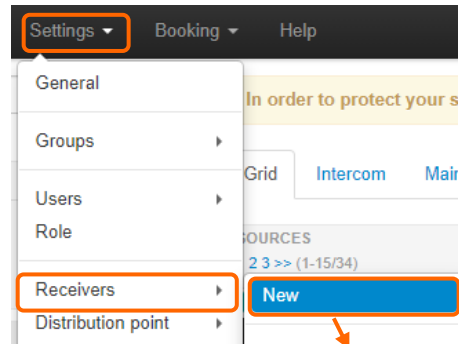

2. In the **Receivers** section, click on **New**.

3. Enter the receiver's LAN or public IP Address.

If the Manager and the receiver are connected to the same LAN, type the local IP address of the receiver.

If the Manager and the receiver are not connected to the same LAN, type the public IP address of the receiver

Set the **TCP Port** used for connecting the Manager to the receiver (i.e. the Manager port as it is configured in the receiver's Connection Settings, by default this is port 7900).

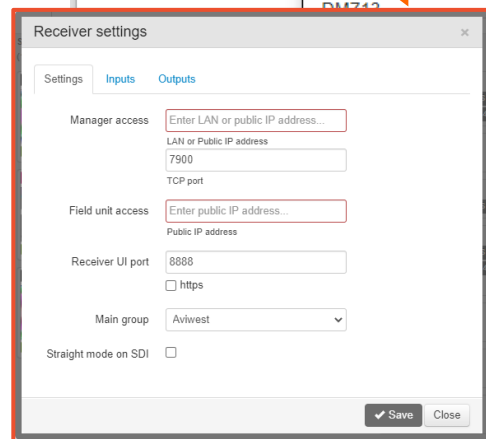

4. Enter the **Public IP Address**, used for connecting field units to the receiver.

Note: You can click on **+** to add an IP address in case you want to ensure a connection redundancy. The field unit will be able to reach the receiver through the 2 addresses configured.

5. Set the **Web UI Port** used by the receiver (by default: 8888).

Note: By ticking the **https** checkbox, you choose to use an https secure connection to the user interface of this receiver from the Manager. Port 443 is usually used for https, but you can modify this port depending on your network properties.

6. In the **Main Group** dropdown list, select the group which the new receiver should belong to.

Note: Provided that no booking is set, this receiver's inputs will be used for field units within this group.

7. Decide if you enable the straight mode for SDI outputs (see [Enabling Straight mode for SDI outputs](#))

8. Click the **Save** button.

The receiver now appears in the list.

Managing User Accounts

Creating User Accounts

Only the administrator can create user accounts.

The administrator can create several user accounts.

1. In the menu bar, click on **Settings**.
2. In the **Users** section, click on **New**.

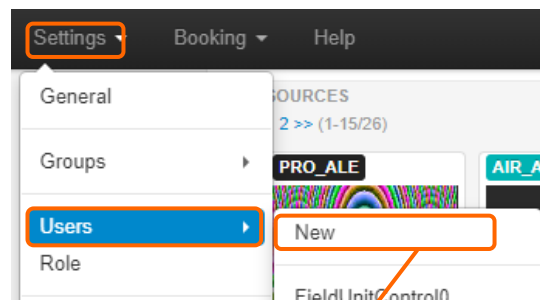

3. Enter a **Login**.
6 characters minimum and 20 characters maximum.

Space and special characters not allowed, except underscore.

You cannot create two user accounts with the same login.

4. Enter a **Password**.

At least 8 characters.

At least 3-character types (lower case, upper case, digit and/or special characters).

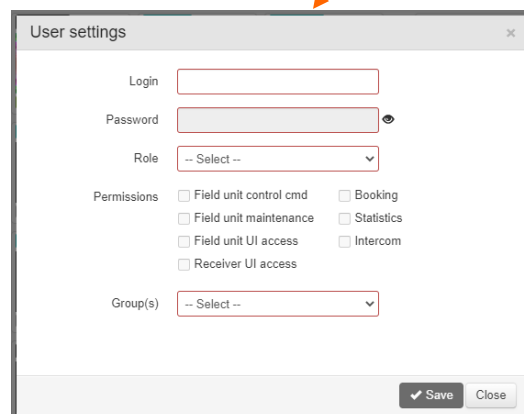

5. Assign a role to the new user by selecting it from the scrolling list.

3 roles are predefined giving specific permissions:

| Permissions | Roles | | |
|------------------------|-------------|-----|------------|
| | Maintenance | MCR | Monitoring |
| Field Unit control | ✓ | ✓ | |
| Field Unit maintenance | ✓ | | |
| Field Unit UI access | ✓ | ✓ | |
| Receiver UI access | ✓ | ✓ | |
| Booking | | ✓ | |
| Statistics | | | ✓ |
| Intercom | | | |

Granted permissions define the scope of actions possible for the user.

| | |
|---------------------------------|---|
| Field unit control | The user can: <ul style="list-style-type: none"> • control the field units <ul style="list-style-type: none"> ○ select a Live profile, start/stop a Live transmission ○ forward, rename or delete files (for DMNG PRO only) • drag and drop in the Grid tab |
| Field unit maintenance | The user can: <ul style="list-style-type: none"> • enable/disable and delete field units from the Manager database. • import a configuration file to field units • update field units remotely • lock the server configuration on field units. • set contact information for a field unit • reset the position of a field unit on the map. • change the group of a field unit. |
| Field Unit web UI access | The user can access to the web page or remote control of the online field units belonging to the group(s) the user will be able to manage. |
| Receiver Web UI access | The user can access the web page of each receiver on which at least one input or output belongs to a group the user is able to manage. |
| Booking | The user can set reservations in the group(s) the user is able to manage. |
| Statistics | The user can access the Stats pages, to set the data amount on SIM cards, to reset the statistics and delete SIM cards. |
| Intercom | The user can start an audio conference between a field unit and the Manager users. |

 **Note:**

From the **Role** scrolling list, you can also select a **Custom** role. This role allows you to choose which permission(s) you assign individually to the new user.

 **Note:**

Permissions assigned to predefined roles (Maintenance, MCR and Monitoring roles) can be modified under **Settings > Roles**.

6. Select at least one group that the user will be able to manage.

 **Note:**

The user can only see receivers that belong to the selected group(s), and/or the receivers that have outputs assigned to these groups.

7. Click the **Save** button.

The user account is successfully created. You can provide the user with the login and password that allows logging in to the Manager web interface.

Modifying a User Account

Only the admin can modify a user account.

1. In the menu bar, click on **Settings**.
2. In the **Users** section, click the user account you want to modify.
3. Modify the **Password**, the **Permissions** or the **Groups** that the user is able to manage.
4. Click the **Save** button.

Note:

Changes are taken into account dynamically.

If this user is already logged in to the Manager, he is not automatically logged out but he is notified of the change.

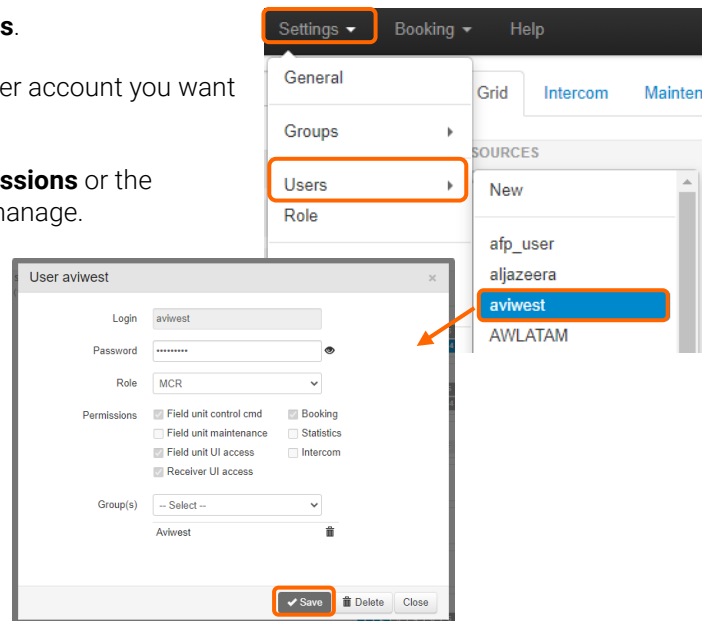

Deleting a User Account

Only the admin can delete a user account.

1. In the menu bar, click on **Settings**.
2. In the **Users** section, click the user account you want to delete.

3. Click the **Delete** button.
A confirmation window opens.

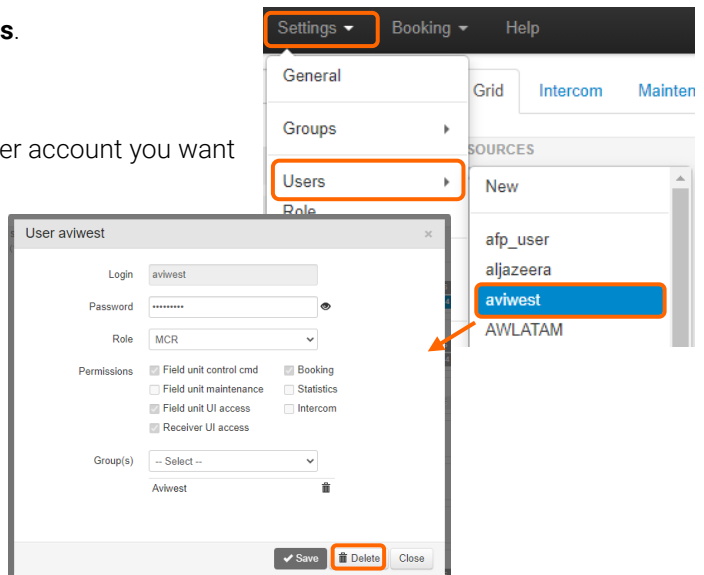

4. Click on **Yes** to delete the user account.

The user account is deleted. If a user was logged in to the Manager web interface with the deleted user account, he is automatically logged out.

Checking a User Profile

When logged in as a user, you can check the permissions you have and the group(s) you are able to manage.

1. In the menu bar, click on your login.
2. Click on **Profile**.

You can see the permissions you have and the groups you are able to manage.

Managing Groups

Changing a Field Unit's Group

The administrator, and users with the "Field unit management" permission who can manage several groups, can change the group of any offline or online field unit.

This operation cannot be performed while a Live, Forward or Record is in progress.

Caution:

When changing the group of a field unit on which a booking is set cancels automatically the booking without any warning.

1. On the Manager interface, go to the **Maintenance** tab.
2. Search the field unit.
3. Click on .
A new window opens.
4. Select another **Group** from the dropdown list.
5. Click on **Save**.

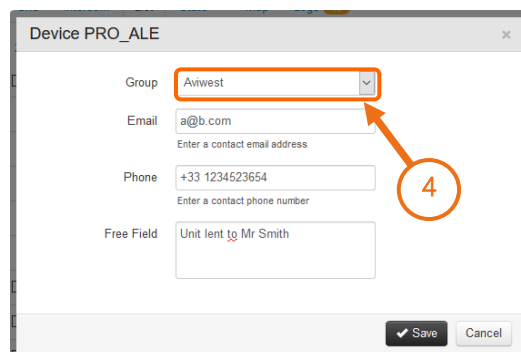

The online field unit is immediately included in the new group.

Following this operation, we recommend editing the Manager profile from the field unit interface with the credentials of the new group that you have selected.

Note:

It is also possible to change the field unit 's group from the field unit panel.

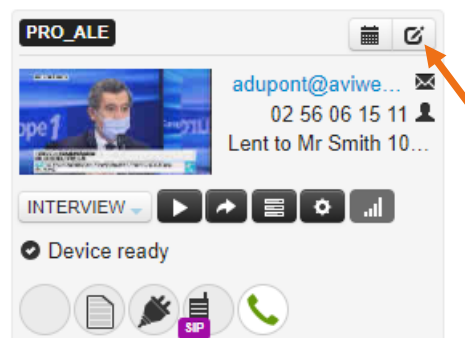

Changing the Receiver's Group

Only the administrator can change the group of a receiver.

1. On the Manager interface, go to the **Maintenance** tab.
2. Search the receiver concerned by the change.
3. Click on .
A new window opens.
4. Go to the **Settings** tab.
5. Select another group from the **Main Group** dropdown list.
6. Click on **Save**.

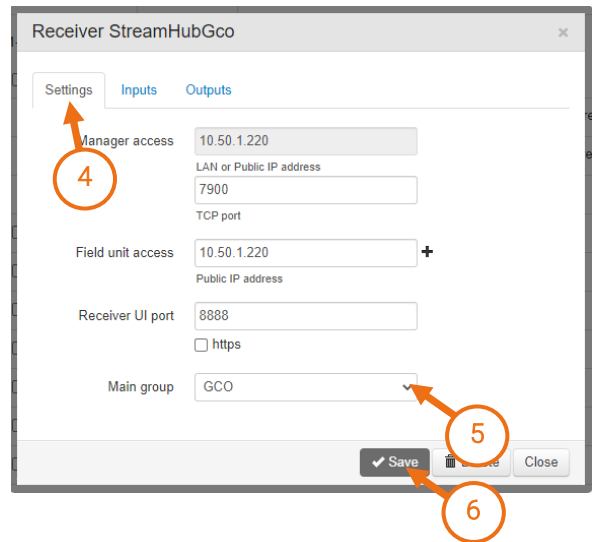

Changing the group of a Receiver's output(s)

Only the administrator can change the group of a receiver's outputs.

This operation is possible only if no booking has been set for this/these output(s).

1. On the Manager interface, go to the **Maintenance** tab.
 2. Search the receiver concerned by the change.
 3. Click on .
A new window opens.
 4. Go to the **Outputs** tab.
 5. Select another group from the **Group** dropdown list.
- The modification is immediately effective.

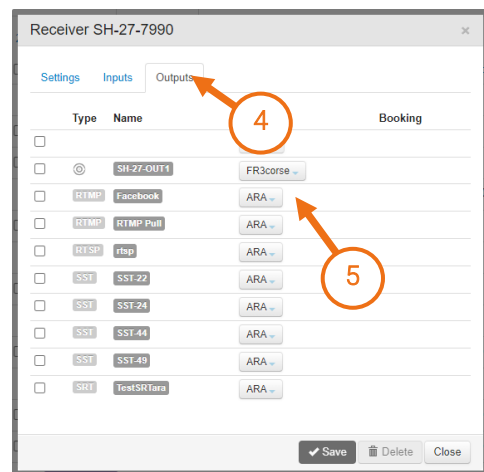

Note:

You can change simultaneously the group of several outputs by ticking checkboxes on the left, selecting the group in the list and clicking on **Save**.

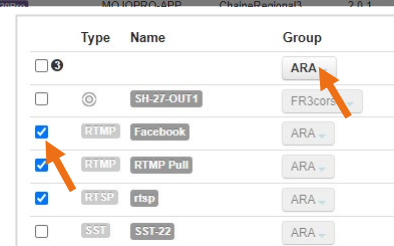

Modifying Receiver Priority

Only the administrator can modify the receiver priority.

1. In the menu bar, click on **Settings**.
2. In the **Groups** section, click the group for which you want to modify receiver priorities within the group.

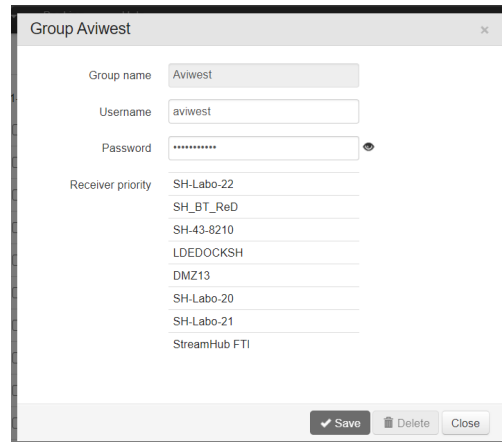

3. In the **Receiver priority** table, drag and drop receivers' name(s) to define priorities.

 **Note:**

Modifications are effective immediately without having to click on Save.

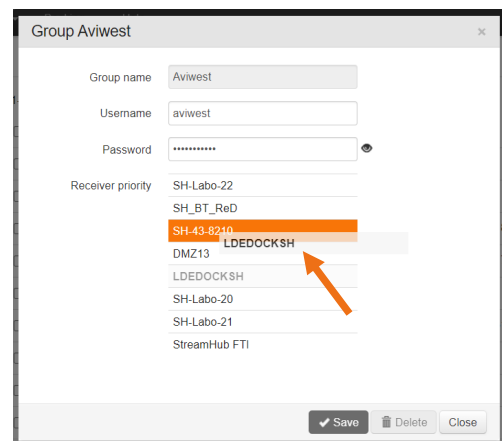

Modifying the Group Credentials

Only the administrator can modify a group's credentials allowing the connection of field units to the group.

1. In the menu bar, click on **Settings**.
2. In the **Groups** section, click the group for which you want to modify the credentials.
3. Modify the **Username** or **Password** for this group.
4. Click the **Save** button.
5. Click the **Close** button.

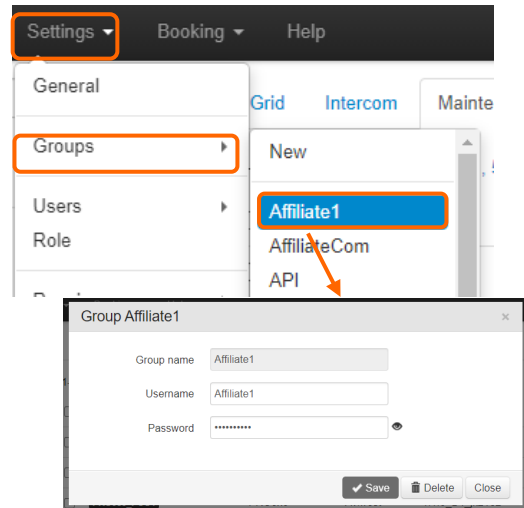

Note:

Changes are immediately effective; the online field units remain connected to the Manager. We strongly recommend editing accordingly the Manager profile on the field units that belong to the group, in order to avoid issue on their next connections.

Deleting a Group

Only the administrator can delete groups.

1. Make sure that there are neither field unit nor receiver associated with the group that you want to delete.
2. In the menu bar, click on **Settings**.
3. In the **Groups** section, click the group you want to delete.
4. Click the **Delete** button.
A confirmation window opens.
5. Click on **Yes** to delete the group.
The group is deleted.

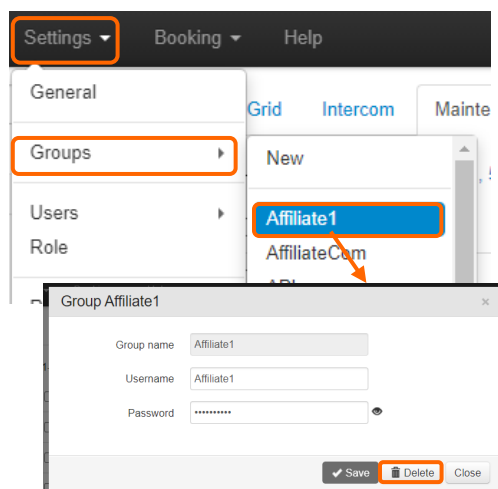

Managing Video Routes

Several functions allow you to manage video routes.

You can:

- Book receiver's outputs for a specific field unit.
- Assign manually a video input to a specific output.

Booking

The administrator, and users with the "Booking" permission, can reserve a receiver's input and output for live transmissions coming from a specific field unit.

You can set a booking either from the Booking menu, the Field Unit panel, or the Output.

Please note that adding a booking on output(s) will automatically book input(s) for this field unit.

Booking from the Booking menu

1. In the menu bar, click on **Booking**.
2. Click the group in which you want to set a reservation.

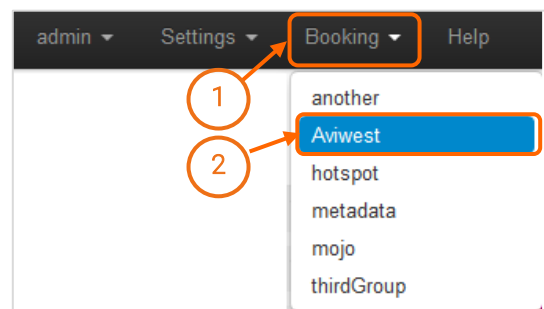

3. In the first dropdown list, select the **Source**.
4. In the second dropdown list, select the receiver on which you want to book an input and optionally an output.

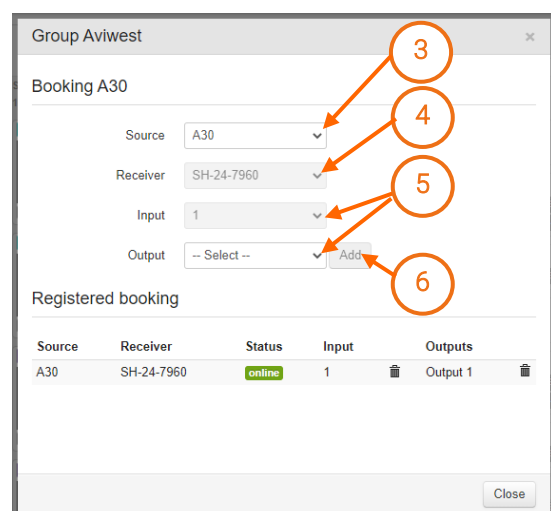

5. Select the input and / or the output to be reserved on this receiver.
6. Click on **Add**.
The new booking is added to the **Registered booking** list.
7. Click the **Close** button.

Booking from the Field Unit Panel

1. From the field unit panel, click on  .

A window opens.

The selected Source is displayed.

2. Select the receiver on which you want to book an input and optionally an output.

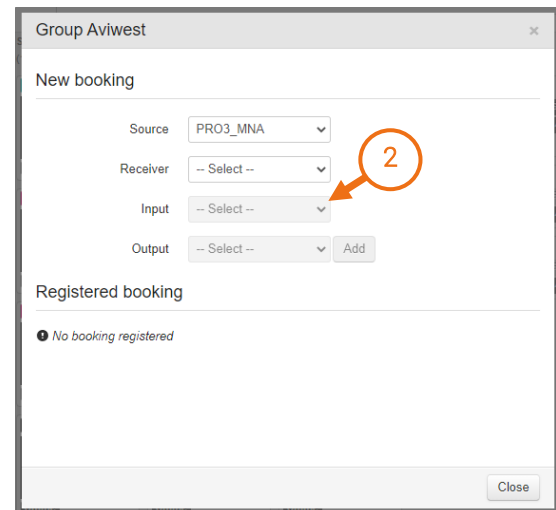
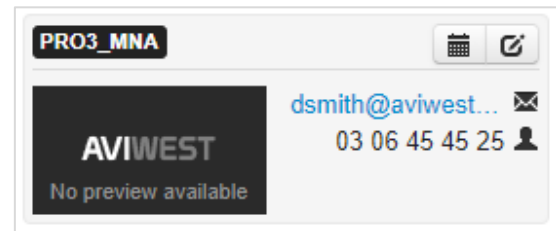

3. Select the input and / or the output to be reserved on this receiver.

4. Click on **Add**.

The new booking is added to the **Registered booking** list.

5. Click the **Close** button.

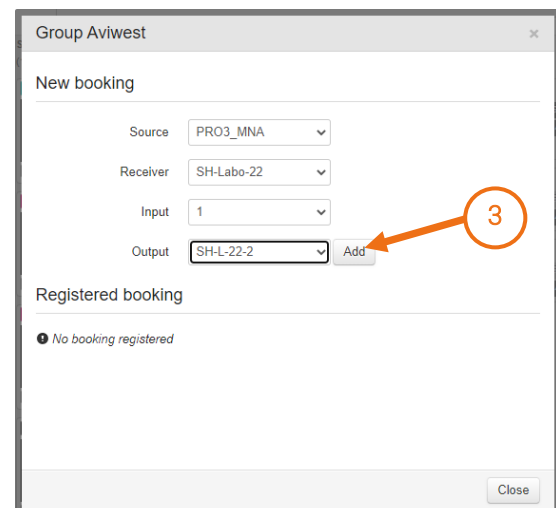

Booking from the Output

1. From the output on the right side of the screen, click on .



2. Select the field unit sending the video source.

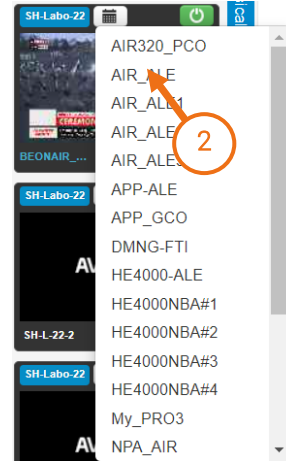



Note: The first available input on the selected receiver is reserved for this field unit. Except if the field unit is running a live. If so, the input used for the Live is booked.

Checking a booking

You can see the booking that you set in different ways:

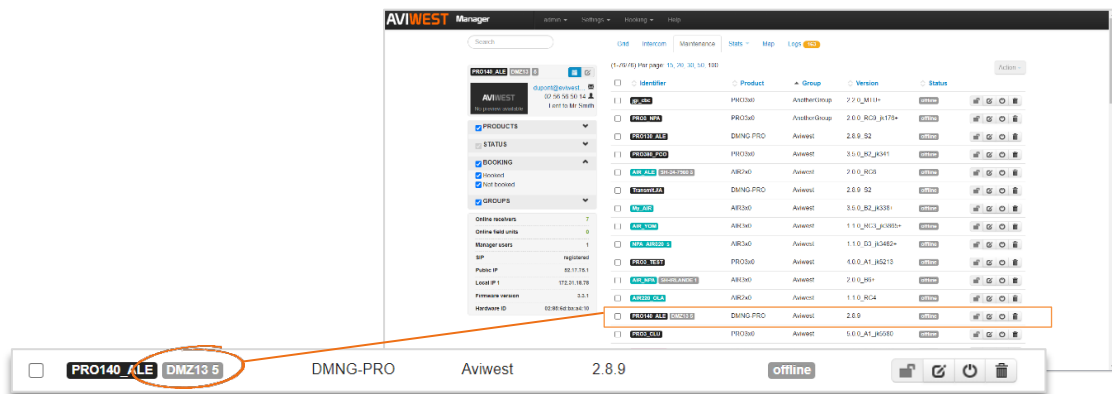
- Under the **Maintenance** tab:
The reserved receiver and input are indicated besides the field unit's name.



- From the field unit panel:
The reserved receiver and input are indicated besides the field unit's name.
The booking button turned to .

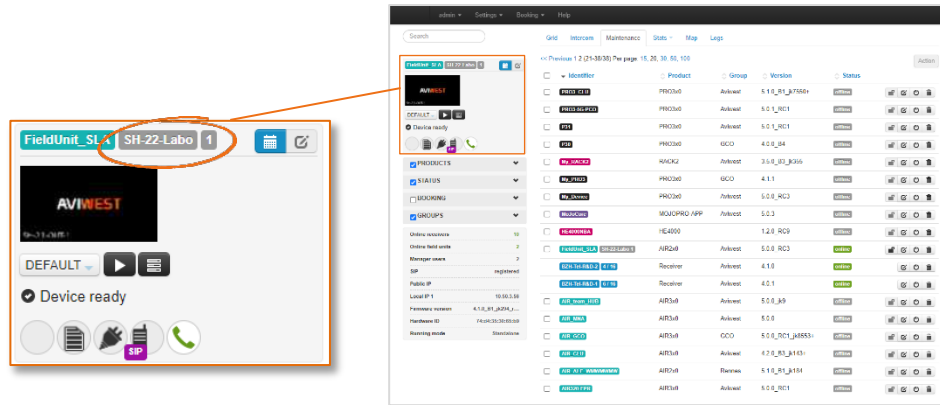

- From the grid view:
The output block indicates the booking that was set for the output.
The booking button turned to .

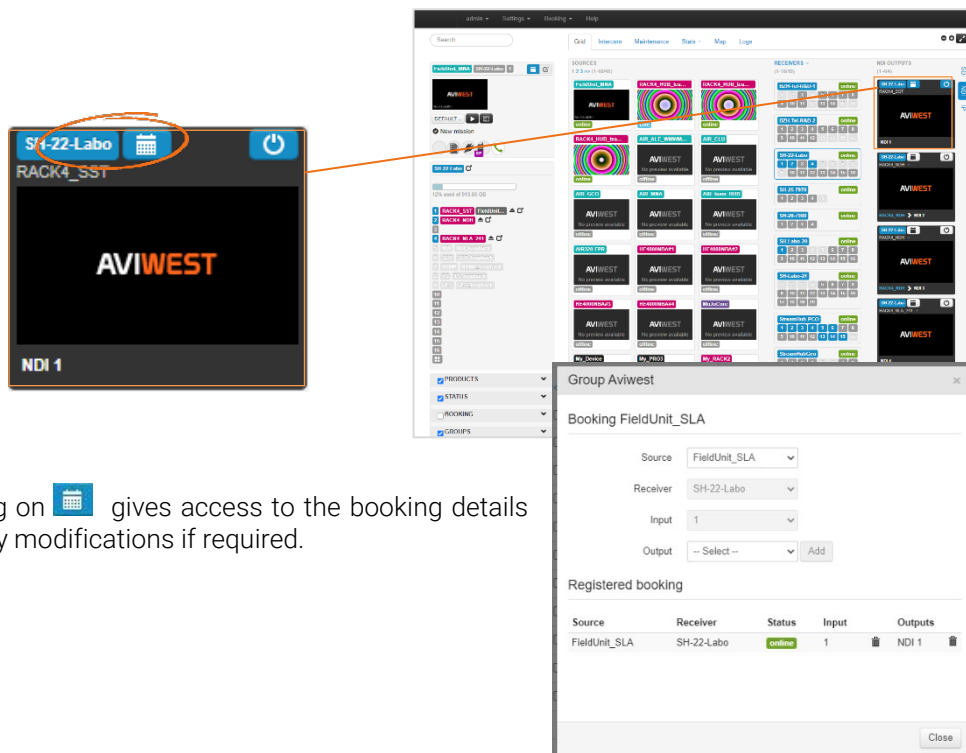

Note:
Clicking on  gives access to the booking details to apply modifications if required.

Cancelling a Booking

You can fully or partially cancel a booking from the booking form.

1. To open the booking form:

- From the Booking menu, select the field unit's group.

- From the field unit panel, click on .

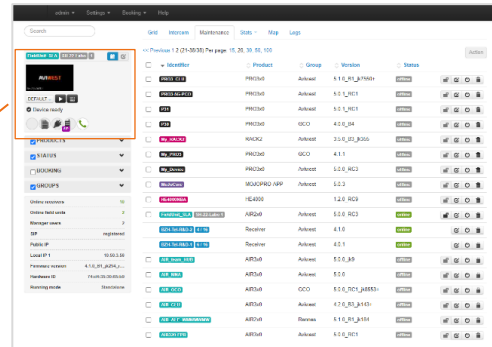
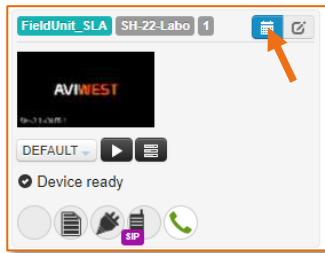

- To cancel the booking for the field unit, click on  (A).

- To cancel the booking on the output, click on  (B).

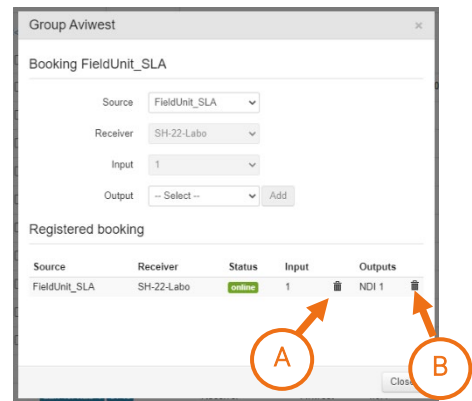



 Note: When the receiver belongs to another group, removing the booking on the last output leads to fully cancel the booking for the field unit. This is to preserve the group coherence.

Cancelling the Booking from the Output

1. From the output block, click on .

2. Untick the selected field unit in the scrolling list.

The button  turns to  and the output is no more booked for the field unit.

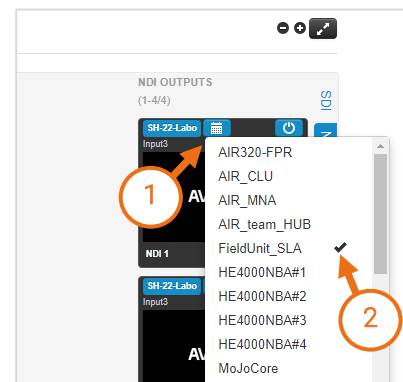

 Note: When this was the last output booked for the field unit, the booking is fully cancelled.

Assigning Resources Manually

The manual assignment allows the administrator, and users with "Field unit control" permission to assign a source to video outputs through a drag and drop action.

Note:

This may modify temporarily the video route that you have set.

Once the live is stopped, the initial settings are restored:

- Initial output state (on/off) as before the Live
- Selected input as before the Live
- Internal lock status as before the Live

1. Go to the **Grid** tab.

You can decide to click on  to enlarge the screen display.

2. If required, use the filters on the left side to display only what you want.

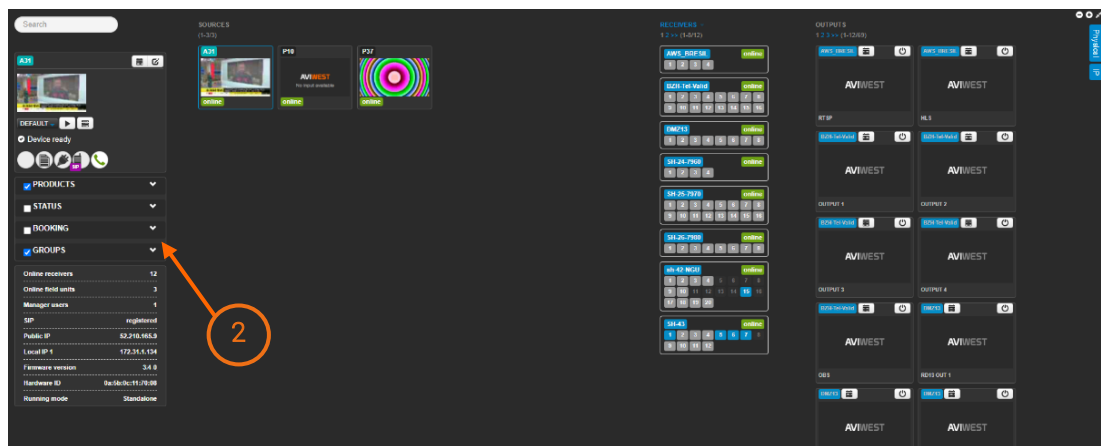

3. Drag the thumbnail of a source and drop it to a receiver's output (target output).

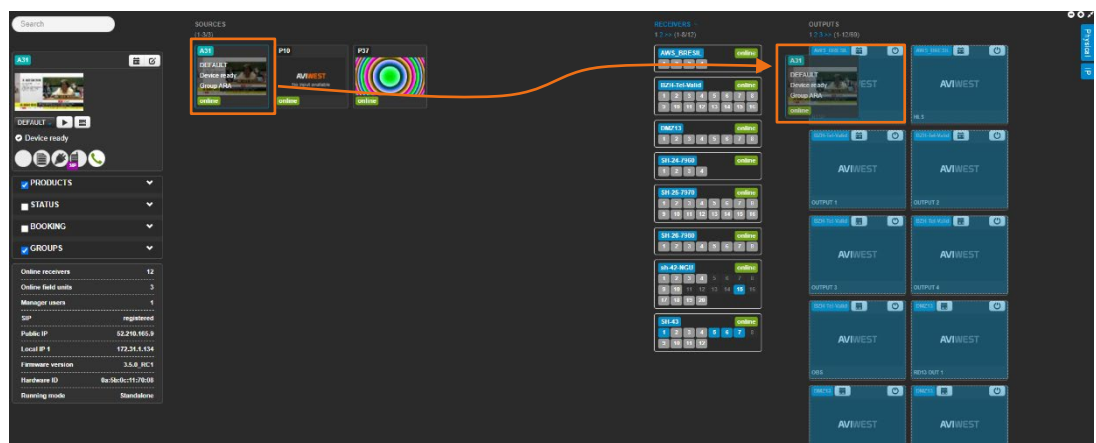

You can do this drag and drop action when:

The field unit is online (with no live action in progress).

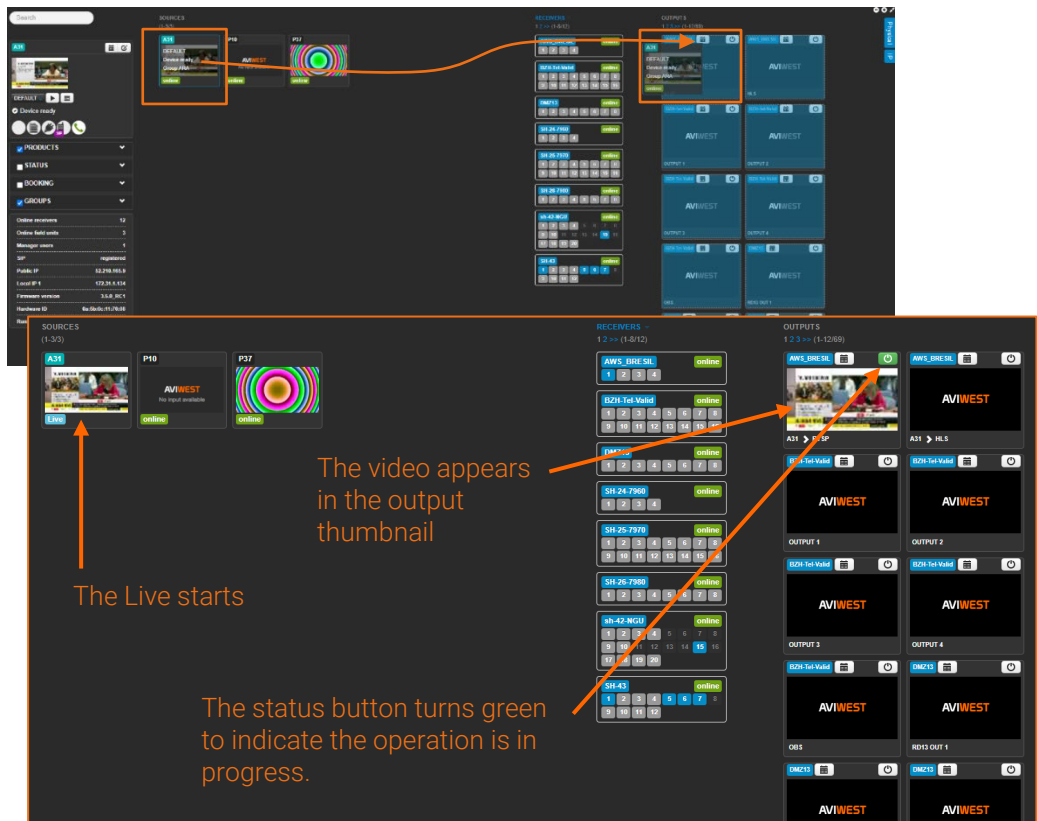

A live action is in progress on the field unit.

- If no output was assigned for the live action in progress, the drag and drop action configures and enables the selected output.

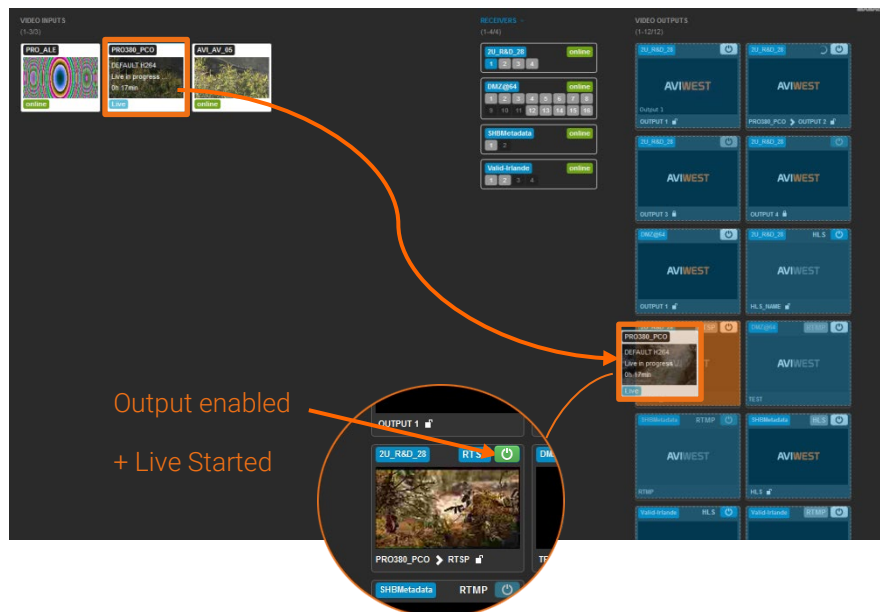

- If an output was already assigned, and you drop the thumbnail onto another output, the video flow is duplicated onto the selected output.

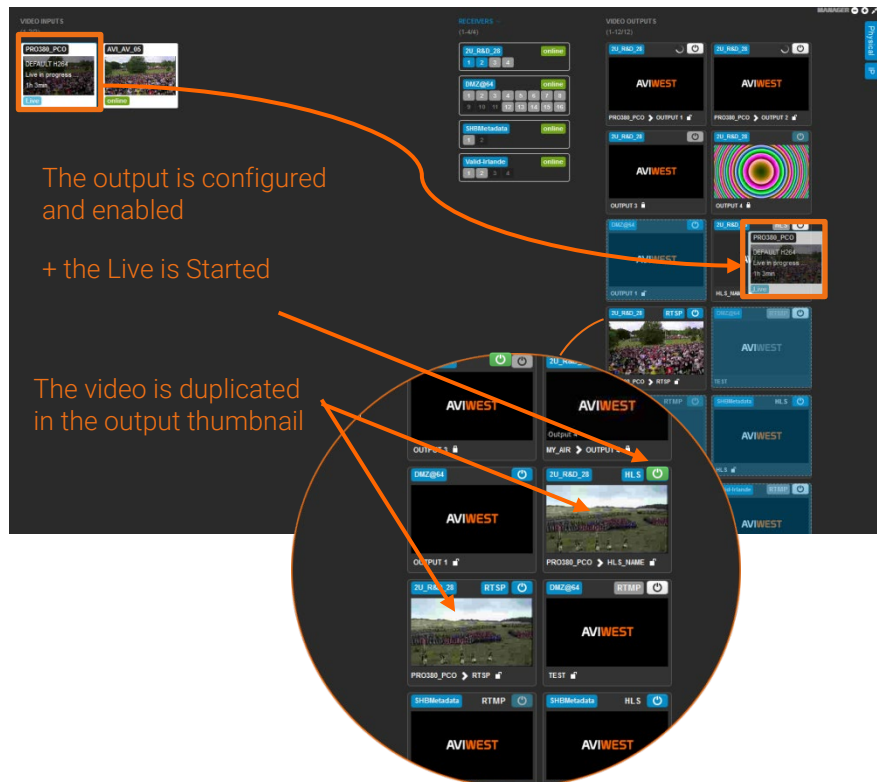

When a live action is in progress on the field unit and you want to use an output of another receiver.



A confirmation message is displayed:



Understanding the default video routes within a group

When no booking is set within a group, some default video routes apply for Live and Forward operations.

Inputs dedicated to Live

For each receiver within a group, some inputs are dedicated to Live operations and other inputs are dedicated to Forward operations.

By default, for each receiver half inputs are dedicated to Live operations while the other inputs are dedicated to Forward operations. Beside here is an example of a 4 inputs receiver.

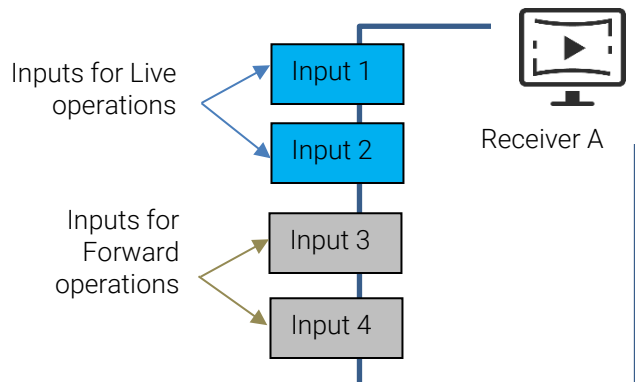

Priorities on Receivers

Priorities on receivers can be defined within a group (see chapter [Modifying Receiver Priority](#)). The default video routes will then respect priorities that have been set.

Live Priorities

When starting a Live, the first dedicated input on the highest priority receiver is used, if available. If not, the next input is used. When all dedicated inputs are used on the priority receiver, the Live is directed towards the dedicated inputs of the next priority receiver.

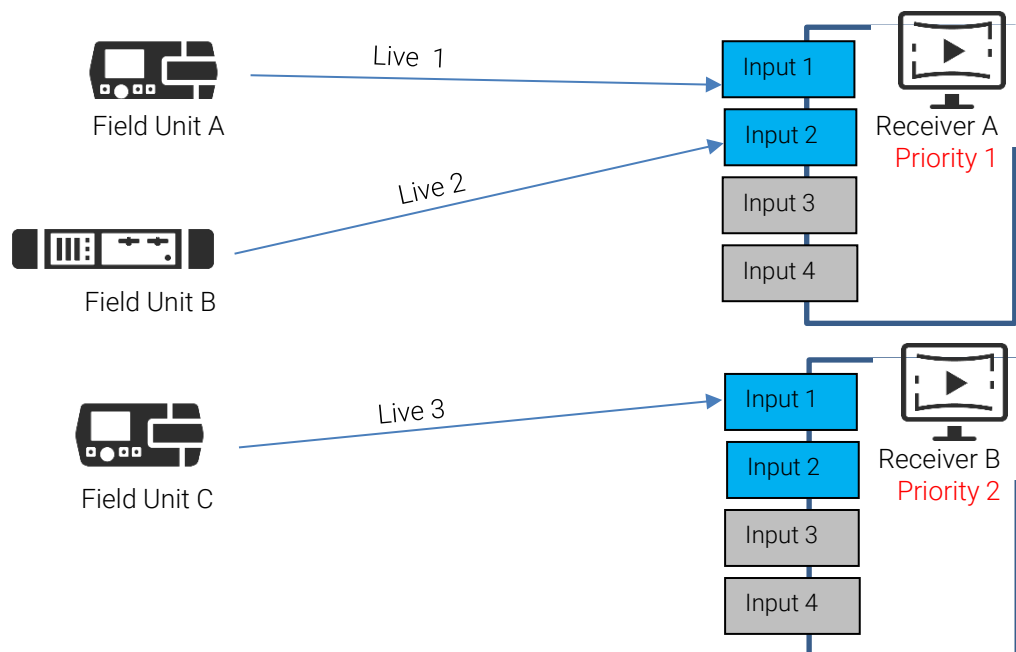

Forward Priorities

Unlike the inputs dedicated to Live operations, the first input dedicated to Forward is the last receiver's input (see diagram below).

When starting a Forward, the first dedicated input on the highest priority receiver is used, if available.

If not, the next input is used. When all dedicated inputs are used on the priority receiver, the forwarded file is directed towards the dedicated inputs of the next priority receiver.

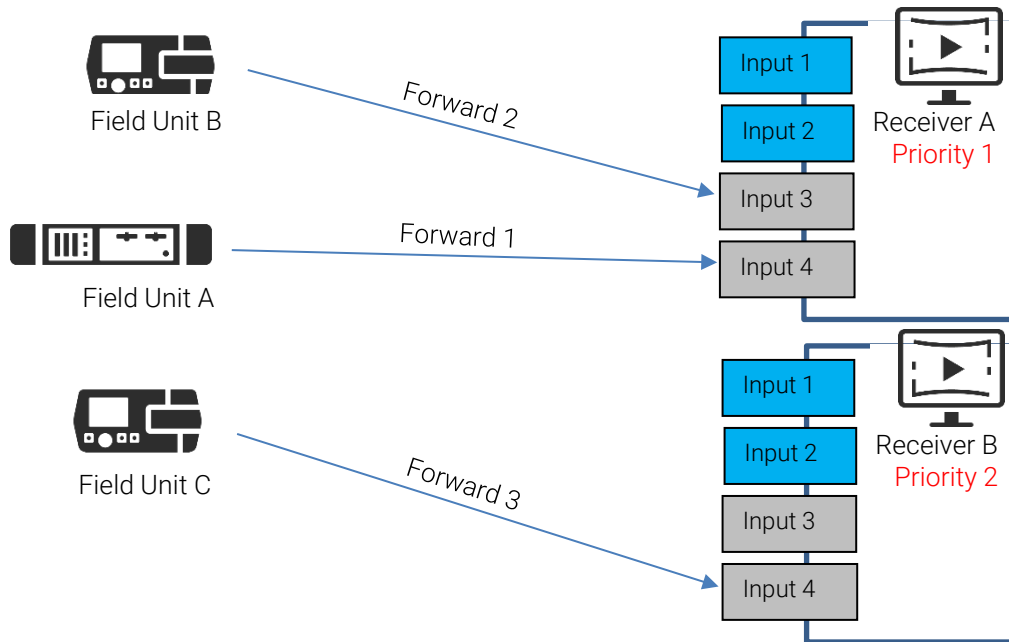

Adjusting the Ratio for Forward and Live Operations

You can easily adjust the number of inputs dedicated to Forward operations and the number of inputs dedicated to Live.

This parameter can be adjusted in the settings of each receiver:

1. In the menu bar, click on **Settings**.
2. In the **Receivers** section, click the receiver for which you want to modify settings.

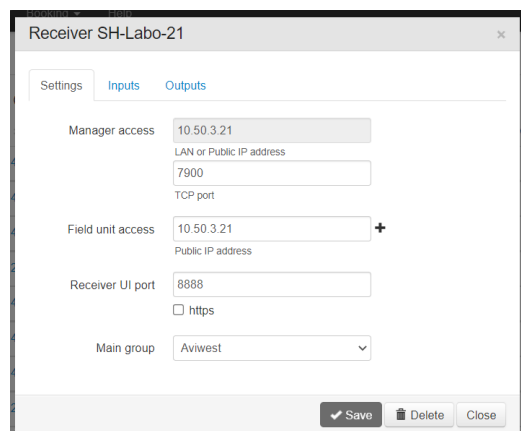

3. Click the **Inputs** tab.
4. Slide the cursor to define the number of inputs dedicated to Live operation, and the number of Inputs used for Forward operation.

In the **Usage** column, all inputs using SST protocol take instantly Live or Forward status, according to the position of the cursor.

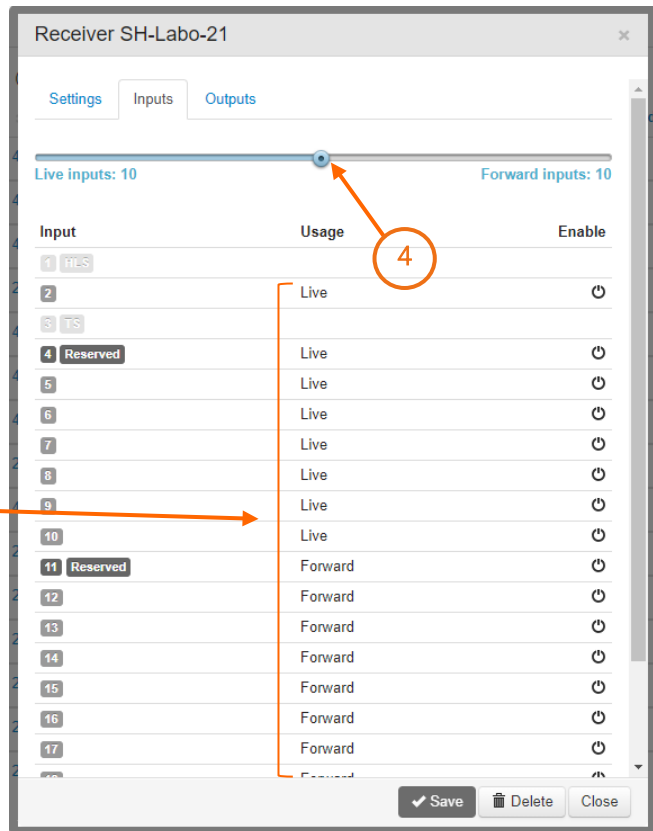

Enabling the Straight Mode for SDI Outputs

You can enable the **Straight Mode** to apply a straightforward workflow when associating inputs to SDI outputs.

When booking inputs and SDI outputs, or using a drag and drop, inputs are locked to their corresponding output number (for bookings, and drag and drops towards SDI outputs):

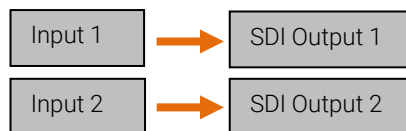

You can enable this **Straight Mode** for each StreamHub separately.

5. In the menu bar, click on **Settings**.
6. In the **Receivers** section, click on the StreamHub for which you want to apply a Straight Mode.

7. Click on the **Straight mode on SDI** check box to enable or disable the mode.

The screenshot shows a configuration window titled "Receiver StreamHub_GCO" with a close button (X) in the top right corner. The window has three tabs: "Settings", "Inputs", and "Outputs". The "Inputs" tab is selected. The configuration fields are as follows:

- Manager access:** IP address field containing "10.50.1.220", with a sub-label "LAN or Public IP address" and a "TCP port" field containing "7900".
- Field unit access:** IP address field containing "10.50.1.220" with a "+" icon to its right, and a sub-label "Public IP address".
- Receiver UI port:** Port field containing "8888" and an unchecked checkbox labeled "https".
- Main group:** A dropdown menu currently showing "Aviwest".
- Straight mode on SDI:** A checked checkbox, with an orange arrow pointing to it from the bottom right.



At the bottom right of the window, there are three buttons: "Save" (with a checkmark icon), "Delete" (with a trash icon), and "Close".

Setting a Video Return for a Field Unit

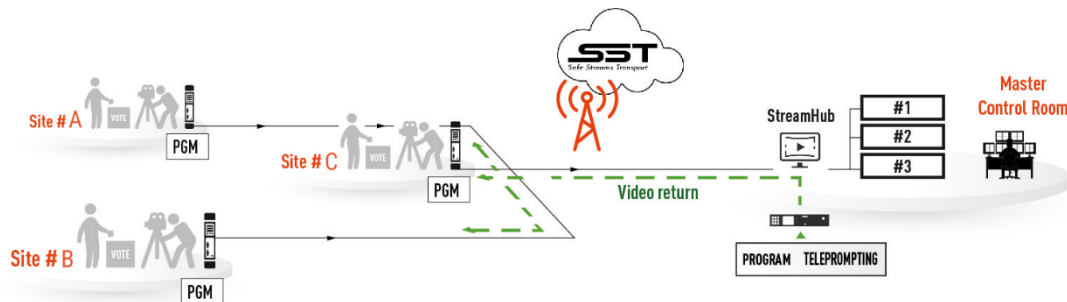
The Video Return feature allows Field Units operating on sites to receive live feeds, such as a program currently on air or a teleprompting from the Media Control Room even if a Live is running or not.



From the Manager interface, you can set a video return for a field unit that is running a live on a StreamHub.

- 1- Open the panel of the field unit for which you want to set a video return.
- 2- Make sure that the field unit is on live.
- 3- Click on the  icon to select a feed from the list of feeds available (Video Return compatible) on this StreamHub.
 - The  icon turns to , indicating that video return is currently running.
 - On the screen connected to the HDMI port of the field unit, you can see displayed the video return feed.

When the live is ended, this video return setting is disabled.

Note:

You can decide that the video return is disabled or not when the live is ended, by clicking on **Settings > General**.

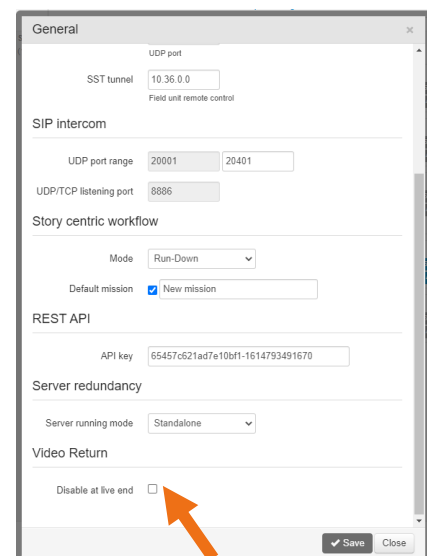

Setting a Distribution Point

You can set a receiver as a distribution point so that video flow can split to several affiliated receivers outside your ecosystem.

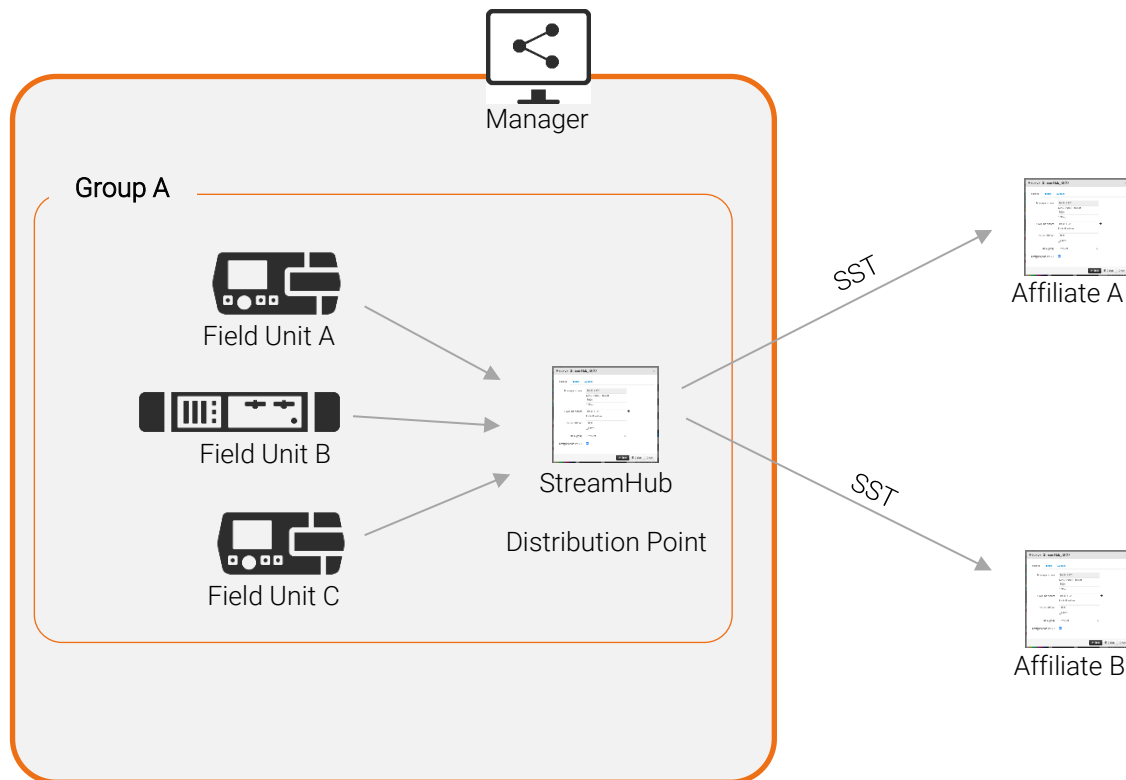

To set a distribution point:

1. In the menu bar, click on **Settings**.
2. In the **Distribution Point** section, click on **New**.

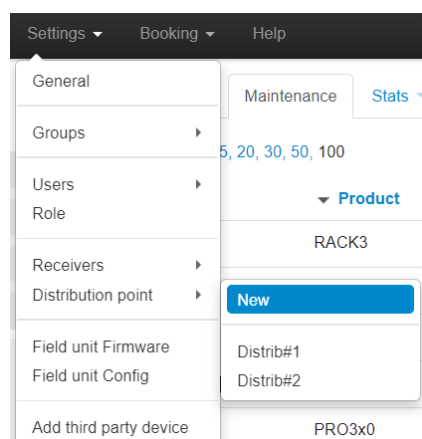

Note:

A group for this new Distribution Point is added and a name is automatically assigned to it.

3. Define access credentials for this new Group (username and password).

4. From the scrolling list, select the relay receiver to become the distribution point.

5. Click on **Save**.

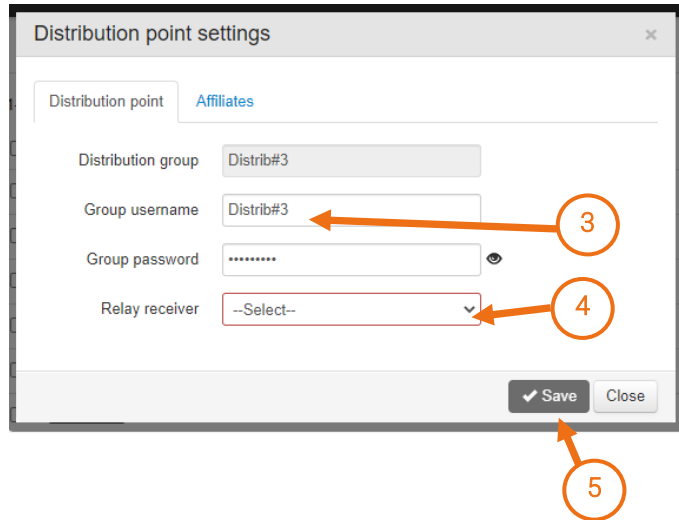

6. Select each **Source** that should be connected to this Distribution Point and click on **Add**.

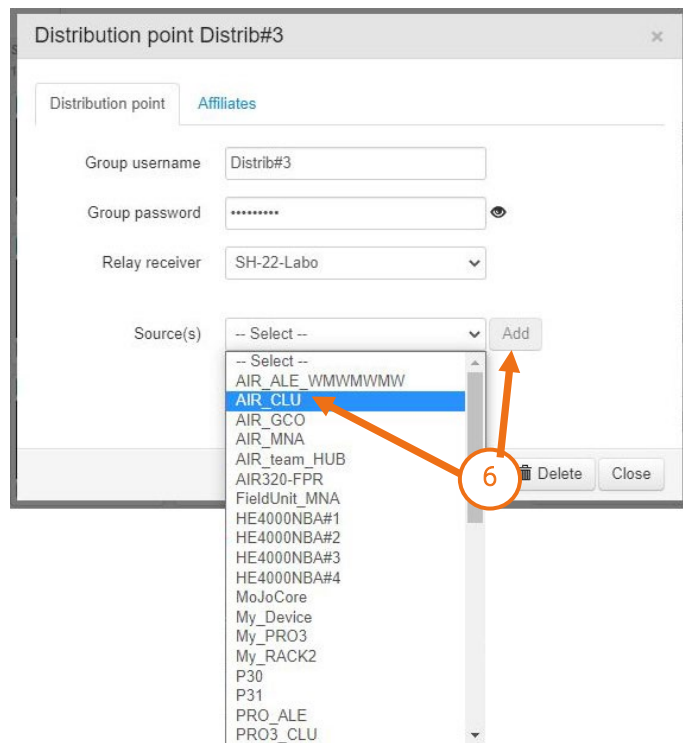

7. Under the **Affiliates** tab, define each affiliate and its associated receiver input settings to be able to receive the video stream from the receiver relay:
 - credentials to access the Manager
 - affiliate receiver address and connection port
 - affiliate receiver input assignment
 - expected latency to the affiliate receiver input

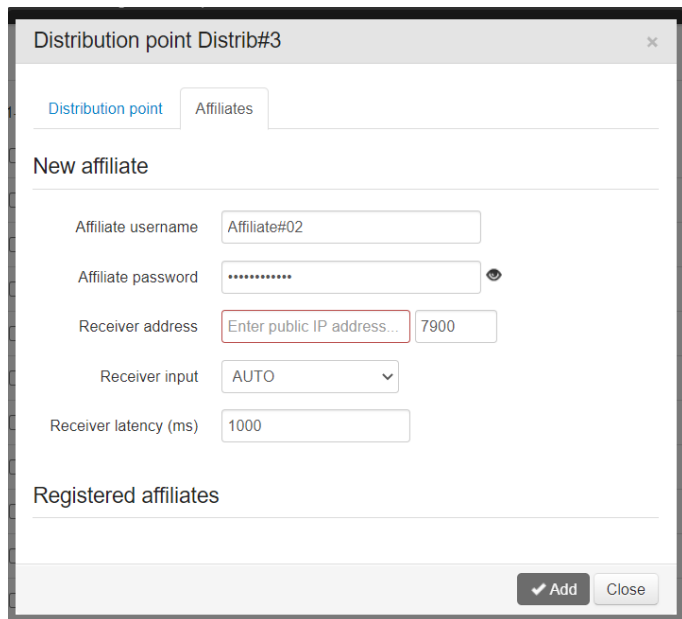

8. Click on **Add** to confirm.

Each affiliate that is added appears under the **Registered affiliates** section.

9. Using the credentials that were assigned to it, each affiliate can connect to a simplified Manager interface.

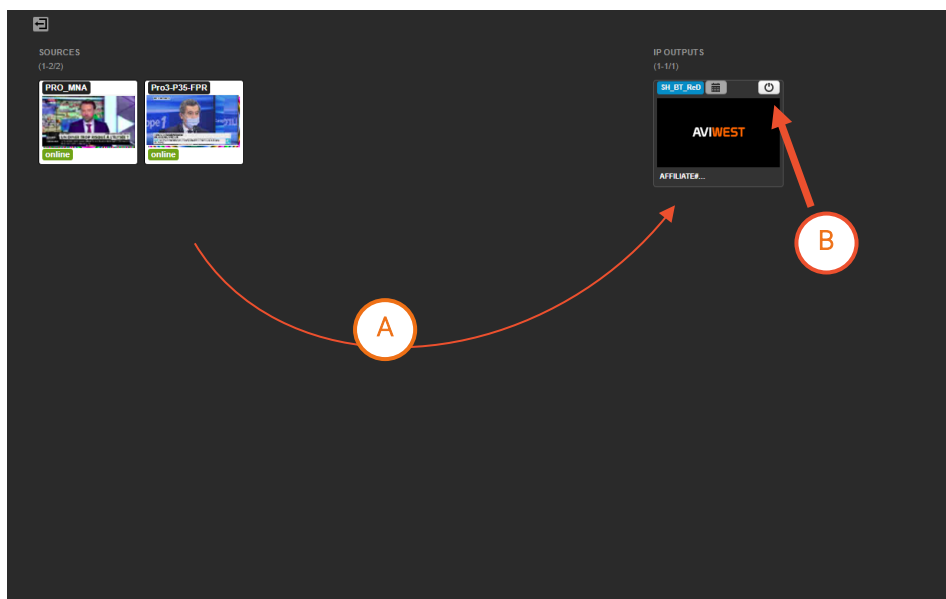

From this interface, the user can see the Sources that were assigned to it.

- A. He can drag and drop a source towards the relay receiver to start a Live.
- B. He can enable or disable the output.

Managing products

Enabling / Disabling Products

By default, all products are enabled.

Disabling a product means temporarily excluding it from automatic assignment, the product disconnects from the Manager, but it remains registered in the Manager database.

Enabling / Disabling a Field Unit

The administrator and users with the "Field unit management" permission can enable / disable any field unit except while it is operating.

1. Go to the **Maintenance** tab.
2. Make sure that filters applied on the side panel allow displaying all field units.
3. Search for the field unit you want to enable / disable.
4. Click on .



Note:

When disabling, a confirmation window opens.

The disabled field unit disconnects from the Manager and is no longer able to connect to the Manager as long as it is disabled.

Enabling / Disabling a Receiver

The administrator can enable / disable a receiver.

1. Go to the **Maintenance** tab.
2. Search the receiver you want to disable.
3. Click on .



Note:

When disabling, a confirmation window opens.

The inputs and outputs of the disabled receiver appear crossed out on the receiver panel and in the Booking window of the group(s) they belong to.

Disabling a receiver excludes its inputs and outputs from automatic and manual assignment.

Disabling a receiver does not stop the action in progress on the receiver's inputs and outputs and on the field units already connected to the disabled receiver.

Deleting Products

Deleting a product means erasing it from the Manager's product database.

Deleting a Field Unit

The administrator and users with the "Field unit management" permission can delete a field unit, except while it is operating.

1. Go to the **Maintenance** tab.
2. Search the field unit you want to delete.
3. Click on .

A confirmation window opens.

4. Click on **Yes** to delete the selected field unit.

The field unit is deleted from the Manager database. Any booking set for this field unit is automatically cancelled.

Statistics gathered for this field unit are deleted, except daily statistics which are kept (including daily statistics gathered for the SIM cards inserted into this field unit).

However, a field unit that has been deleted is still able to connect to the Manager as a new product.

Deleting a Receiver

The administrator can delete receivers from the Manager database.

Deleting a receiver, results in deleting reservations for live transmissions. Deleting a receiver while one or several inputs are receiving a video stream (Live or Forward) does not stop the action(s), but the receiver's inputs are no longer available for automatic or manual assignment.

1. Go to the **Maintenance** tab.
2. Search the receiver you want to delete.
3. Click on .

A confirmation window opens.

4. Click on **Yes** to delete the selected receiver.

 **Note:** You can also delete a receiver from the connection settings window of the receiver (**Settings** menu > **Receiver**).

Modifying the Connection Settings of a Receiver

Only the administrator can modify the connection data of a receiver.

1. In the menu bar, click on **Settings**.
2. In the **Receivers** section, click the receiver for which you want to modify the settings.
3. Modify the **Public IP address** and/or **Port**.
4. Click the **Save** button.

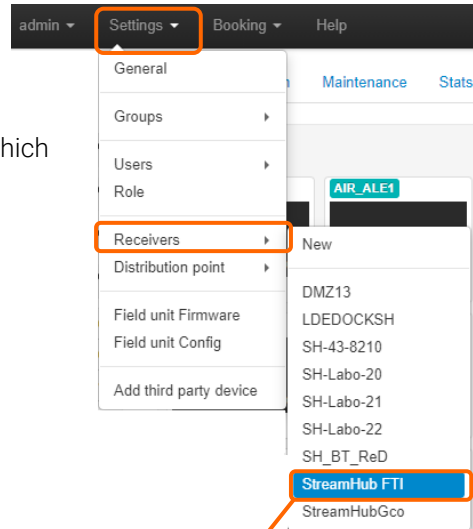

Changes are taken into account for any new connection of field unit to this receiver, but they do not impact the field units already connected to the receiver.

 **Note:**

You cannot modify the IP address used for connecting the Manager to the receiver. If you need to modify this setting, you have first to delete the receiver, and then add it again with the new IP address.

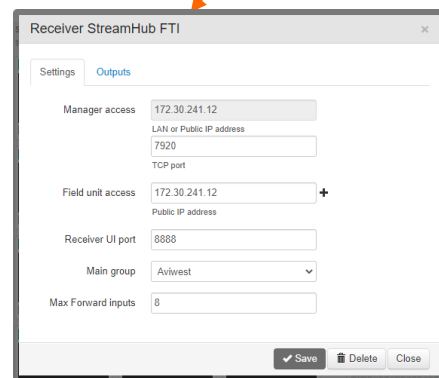

Managing Field Units

Updating Field Units' Firmware

The administrator, and users with the "Field unit management" permission, can remotely manage the updates of field units' firmware.

Prior to initiating the update, you need to upload files into the Manager database.

1. In the menu bar, click on **Settings**.

2. Click on **Field unit Firmware**.

A new window opens.

3. Click the **Browse** button.

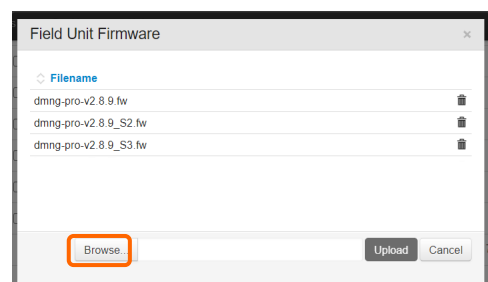

4. Choose the .fw file you want to load.

5. Click the **Upload** button.

The uploaded file appears in the Firmware list.

6. Click the **Close** button.

The file is now available for performing remote updates.

7. Go to the **Maintenance** tab.

8. Select the field unit(s) you want to update, using the checkbox(es) on the left of the identifiers.

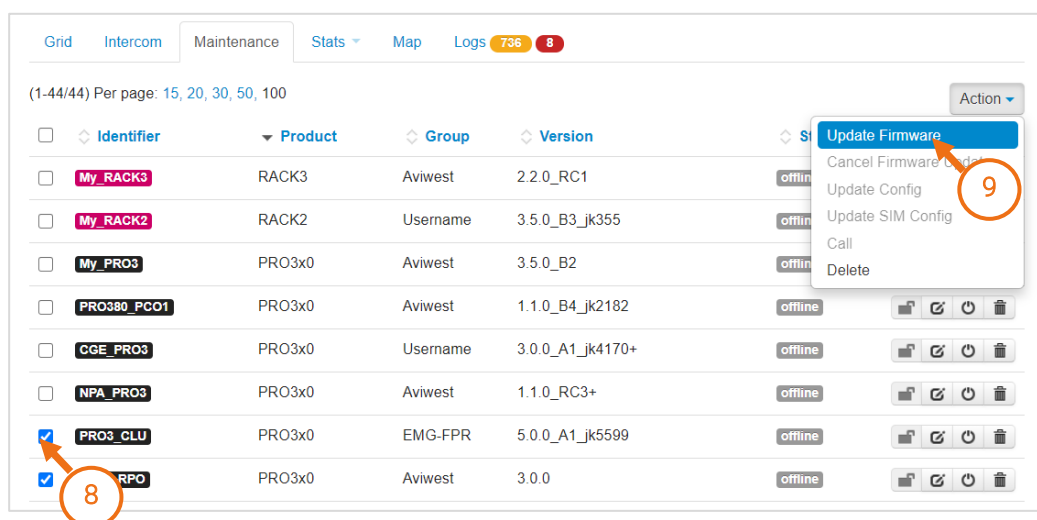

9. Click on the **Action** button and select **Update Firmware**.

As a result:

- For the online field units: a message appears on each field unit so that the user can accept or postpone the update.
- For offline field units and operating field units (i.e. when a Live, Store or Forward is in progress): a clock appears aside the version number.
- For offline field units as well as field units on which the update has been postponed: a message appears on the field unit on each next start or next connection to the Manager so that the user can proceed to the update or postpone it.
- If the user has postponed the firmware update, the message "Declined update request" is prompted.

 **Note:**

- If needed, you can cancel a pending update (**Action > Cancel Firmware Update**).

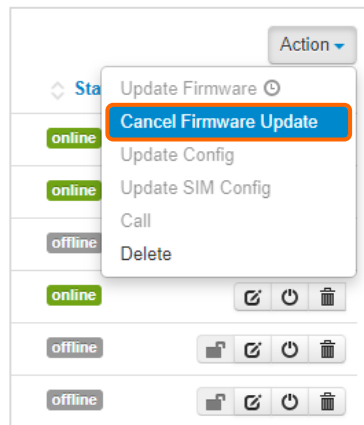

- You can also delete firmware versions from the database, except if an update is pending or ongoing on a field unit with selected the version.

On the row corresponding to the file to delete, click on .

Updating Field Units' Configuration

The administrator, and users with the "Field unit management" permission, can remotely configure one or several field units simultaneously (Main Configuration or SIM Configuration).

First you need to upload a configuration file into the Manager database.

Then you can import this configuration file onto a selection of field units.

Uploading a configuration file

1. In the menu bar, click on **Settings**.
2. Click on **Field unit Config**.

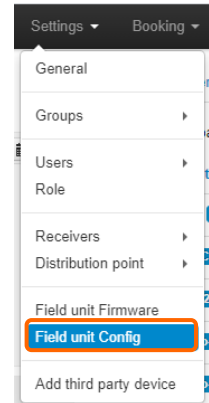

A new window opens.

3. Click the **Browse** button.
4. Select the .conf or .awj file you want to upload.
5. Click the **Open** button.
6. Click the **Upload** button.
7. Once the uploaded file appears in the list, click the **Close** button.

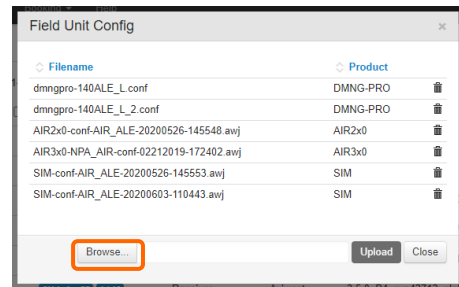

The file is now available for performing remote updates or remote configuration from an existing file.

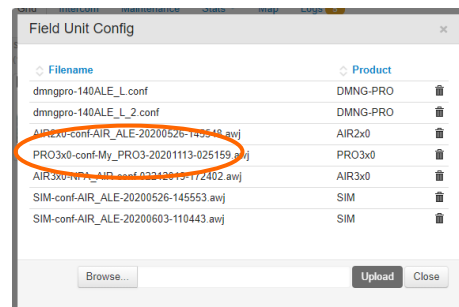

Note:

If needed, you can delete configuration files from the database, except if an update is pending or ongoing on a field unit with selected the version. On the row corresponding to the file to delete, click on  ..

Updating a Configuration File on a Field Unit

1. Go to the **Maintenance** tab.
2. Select one or several online field units using the checkbox(es) on the left of the identifiers.

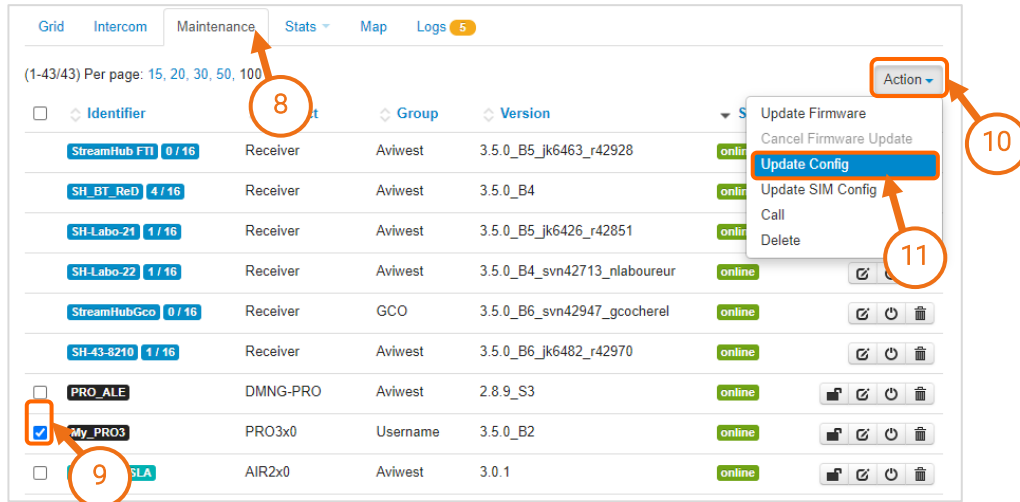

3. Click the **Action** button.
4. Click on **Update Config** or **Update SIM Config**.

The Config Update window opens.

5. Select the configuration file to import.

The Manager imports the configuration file onto the selected online field unit(s).

It does not import the configuration file onto offline field units and onto field units on which a Live, Forward or Record is in progress.

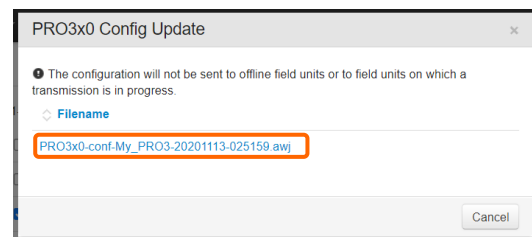

Locking the Server Profile on a Field Unit

The administrator and the users with the "Field unit management" permission can lock the server profiles on an online field unit.

1. On the Manager interface, go to the **Maintenance** tab.
2. Search the online field unit on which you want to lock the server profile.
3. Click on .

The button is then .

The server configuration pages are locked on the touchscreen of the field unit and on its Web Interface. The field unit user is no longer able to select another server to connect to, as well as to add, edit or delete server profiles.

Controlling Field Units Remotely

From the Manager interface, you can remotely control online field units.

You can:

- access to the Remote User Interface of the field unit.
- access to the Web User Interface of the field unit.

Accessing the Remote User Interface of a Field Unit

1. Go to the **Map, Maintenance** or **Grid** view.
2. Click the field unit's name to prompt the field unit panel in the upper left corner of the page.
3. In the field unit panel, click on .

The remote window opens. You have now full remote control of the field unit.

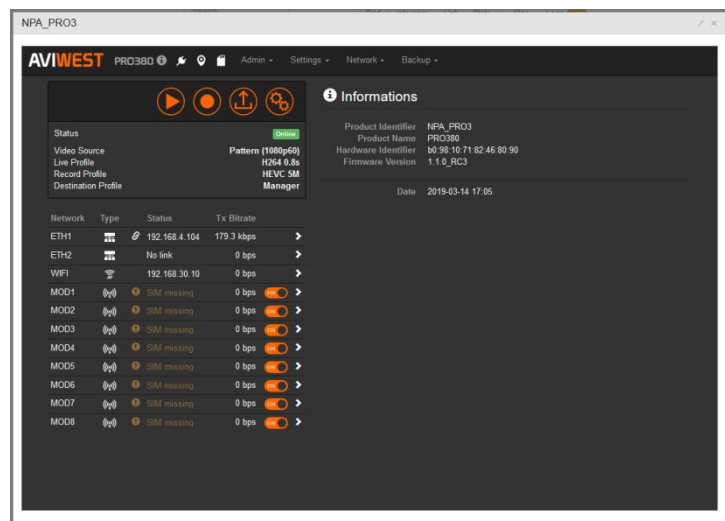
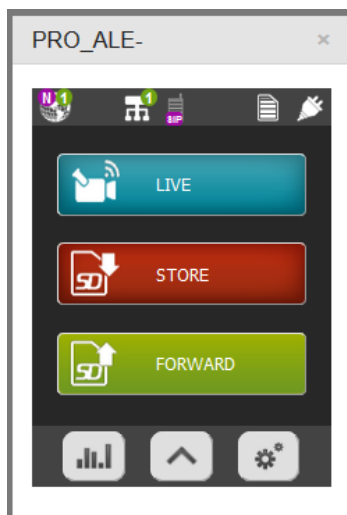

Note:

For more information about using the field units, please refer to the respective User Guides.

Some actions performed from the remote interface result in disconnecting the field unit from the Manager.

Accessing the Web Configurator of a DMNG PRO 1x0

You can configure an online DMNG PRO through its Web Configurator.
While it's operating, its configuration can only be read.

1. Go to the **Map, Maintenance** or **Grid** view.
2. Click the Pro's name to prompt the field unit panel in the upper left corner of the page.
3. In the field unit, click on .



The field unit Web Configurator opens.

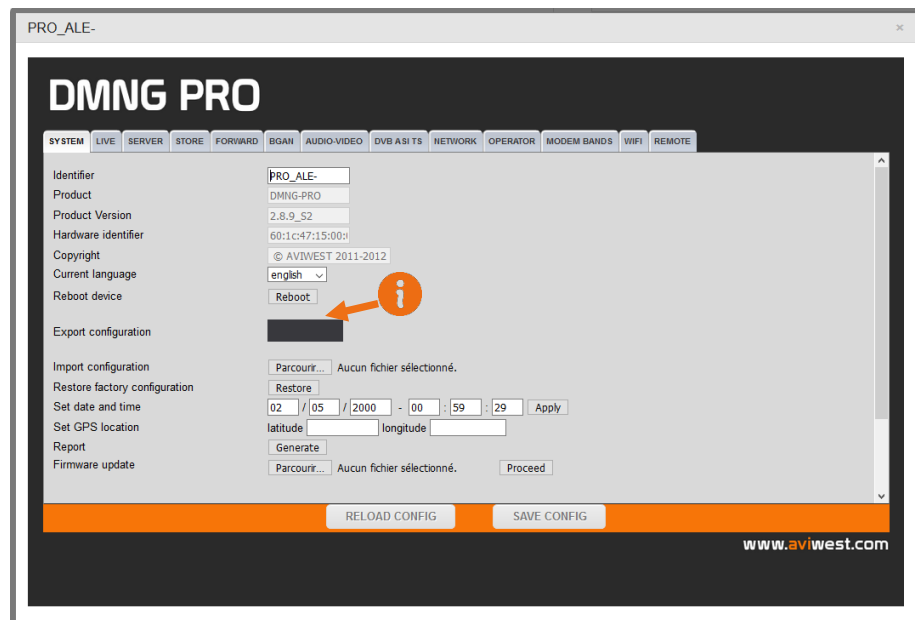



-  As Flash Player is no longer supported since January 2021, exporting the configuration is not possible.

Please refer to the field unit configuration Guide.

4. After modifying settings on a tab of the Web Configurator, click the **SAVE CONFIG** button to save the modifications.

Starting a Live

1. Go to the **Map, Maintenance** or **Grid** view.
2. Click the field unit's name to prompt the field unit panel in the upper left corner of the page.
3. In the field unit panel, select a Live profile from the dropdown list.
Click on  to start the live transmission.
4. Click on  to stop the live transmission.

The live transmission stops and the field unit disconnects from the receiver input.

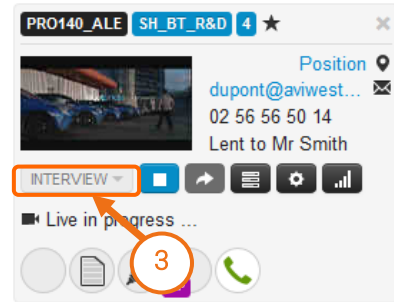

Managing Files

From the field unit panel on the left side of the screen, you can easily manage PRO1x0 files (forwarding, deleting, and renaming them).

For other field units such as AIR Series, PRO3 Series, you must use the remote access functionality via the  button.

Forwarding Files

1. Go to the **Map, Maintenance** or **Grid** view.
2. Click the field unit's name to prompt the field unit panel in the upper left corner of the page.
3. In the field unit panel, click on .
4. Select the mass-storage device on which is saved the files to forward.
A new window opens.
5. Click the file name(s) to select the file(s) you want to forward.
6. Click the **Forward** button.

The file forwarding starts. It automatically stops once the receiver successfully received the forwarded files.

Note:

If needed, you can stop forwarding files by clicking on



If so, the field unit disconnects from the receiver's input and the receiver does not complete the file until you resume the Forward and wait until it ends (on restarting, it resumes exactly where it stopped).

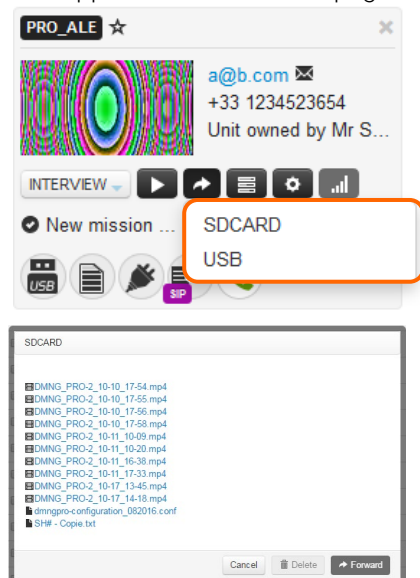

Deleting Files

1. Go to the **Map, Maintenance** or **Grid** view.
2. Click the field unit's name to prompt the field unit panel in the upper left corner of the page.
3. In the field unit panel, click on .
4. Select the mass-storage device containing the file(s) to delete.
A new window opens.
5. Click the file name(s) to select the file(s) you want to delete.
6. Click the **Delete** button.
A confirmation message prompts you to confirm that you want to delete the selected files.
7. Click the **Yes** button to delete the file(s).

Renaming Files

1. Go to the **Map, Maintenance** or **Grid** view.
2. Click the field unit's name to prompt the field unit panel in the upper left corner of the page.
3. In the field unit panel, click on .
4. Select the mass-storage device containing the file to rename.
A new window opens.
5. Double-click the file name(s) to edit.
6. Edit the file name.
7. Press the Enter key on your keyboard.
The file is renamed.
8. Click the **Cancel** button to close the window.

Managing a receiver

From your Manager, you can do some actions on receivers such as disconnecting a field unit, managing outputs and accessing remotely to their user interfaces.

Disconnecting a field unit from the receiver

To disconnect a field unit from a receiver:

1. Go to the **Maintenance** or **Grid** view.
2. Search the receiver that you want to control.
3. Click the receiver's name to prompt the receiver panel in the upper left corner of the page.
4. Click on .
5. Click on **Yes** to confirm your choice.

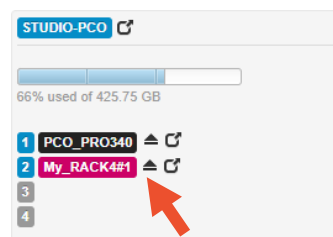

Managing outputs

From your Manager, you can enable/disable receivers' outputs, or modifying inputs assigned to outputs.

Enabling / disabling an output

From the **Grid** view, it is easy to enable / disable an output.

1. Click on the type of output on the right side (SDI/ NDI/IP).
2. Search for the output thumbnail and click on  to enable or disable the output.



Modifying the input on an output

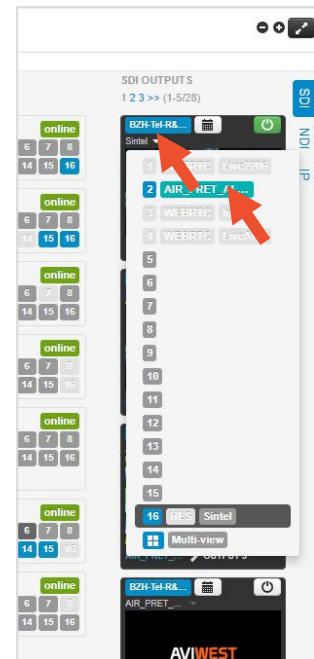

From the **Grid** view, it is easy to select another input for an output.

1. Search for the output thumbnail.
2. From the drop list, select the input that you want to assign to output.



Accessing the Receiver's Interface Remotely

The administrator and the users with the "Receiver Web UI Access" permission can access the web page of any online receiver.

1. Go to the **Maintenance** or **Grid** view.
2. Search the receiver that you want to control.
3. Click the receiver's name to prompt the receiver panel in the upper left corner of the page.
4. Click on  located in the receiver panel, to access the dashboard of the receiver or on  located beside the input to directly access the receiver on the input page.

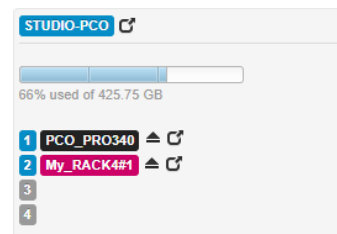

The receiver web page opens in a new tab.

Please refer to the StreamHub User Guide for details.

 **Note:** When logged in to the Manager as administrator, you access the receiver as admin. When logged in to the Manager as user, you access the receiver as user.

Monitoring an Ecosystem

You can use the **Maintenance**, **Grid** and **Map** tabs to monitor the full ecosystem at a glance.

Using filters

To help you in displaying only the elements that you wish to monitor, you can use the filters on the left side of the screen.

- You can select which Products and which Groups you want to display.
- You can also filter by Status, or by Booking.

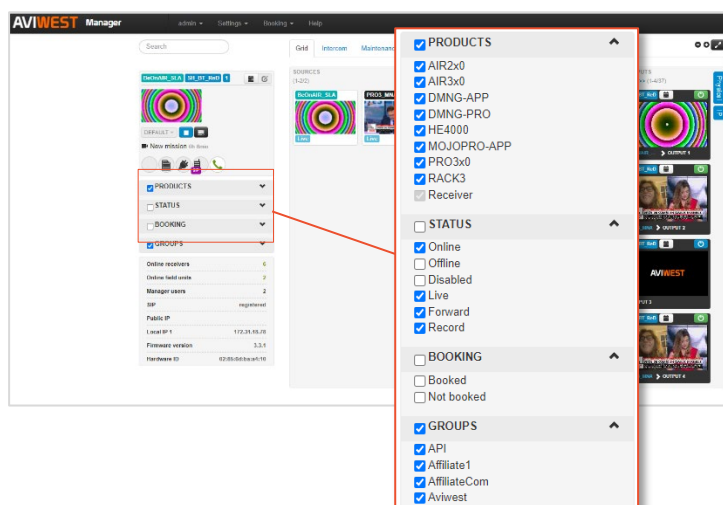

Note: For more convenience, filters that you applied are saved in your browser.

Monitoring the Field Units

The **Maintenance** and **Grid** tabs give 2 different views from which you can monitor the field units.

The Grid tab

Field unit thumbnails indicate the status of each field unit connected to the Manager.

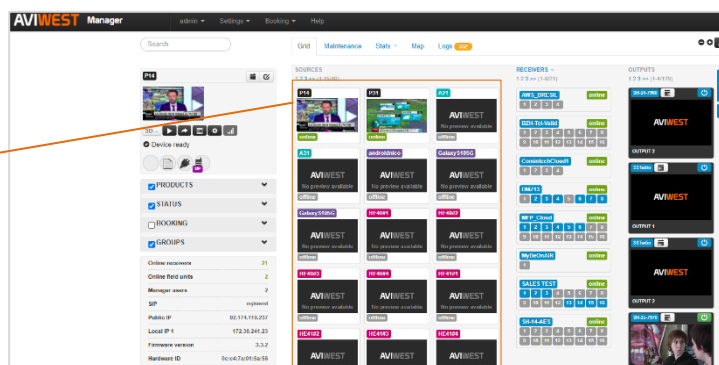

When placing the mouse over a thumbnail, information about the field unit appears:

- The Live Profile
- The name of the selected mission (if using story centric workflow)
- The group the field unit belongs to
- Live / Forward duration

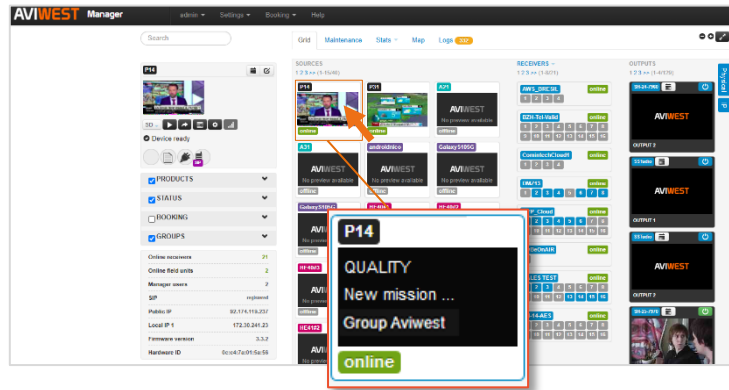

Note: This information is refreshed every minute.

The Maintenance tab

Each line gives details about field units and receivers connected to the Manager.

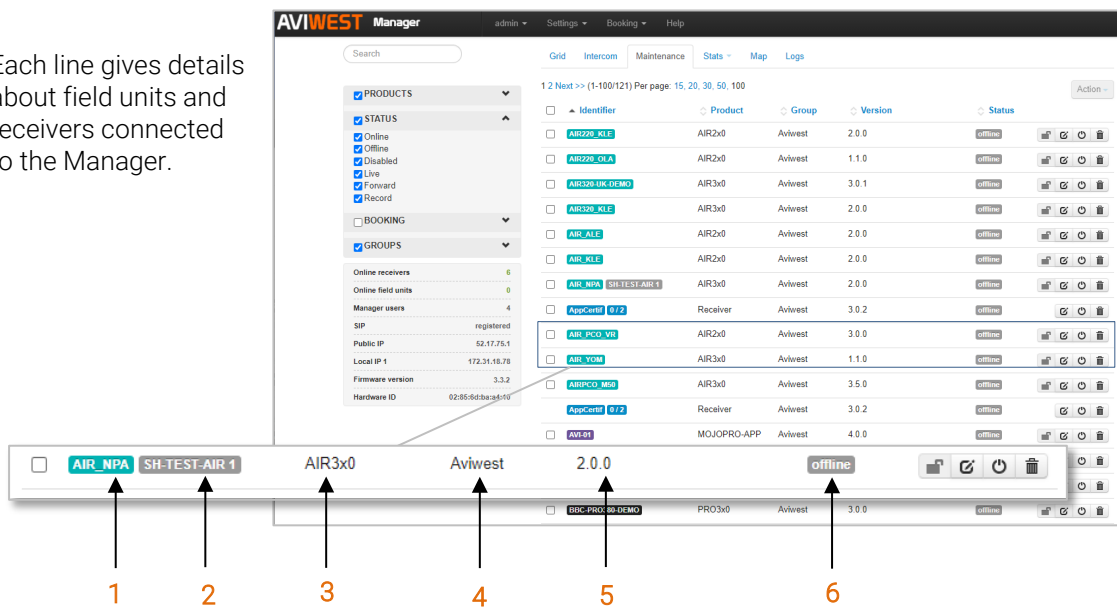

| | |
|----|---|
| 1 | Transmitter / Receiver Name |
| 2* | Reservation Set to an input of a Receiver |
| 3 | Type of Field Unit |
| 4 | Group that the Field Unit belongs to |
| 5 | Firmware version of Field Unit |
| 6 | Status of the Field Unit |

* Please note that this is the reserved input number. To see the potentially reserved output(s), go to the Booking menu.





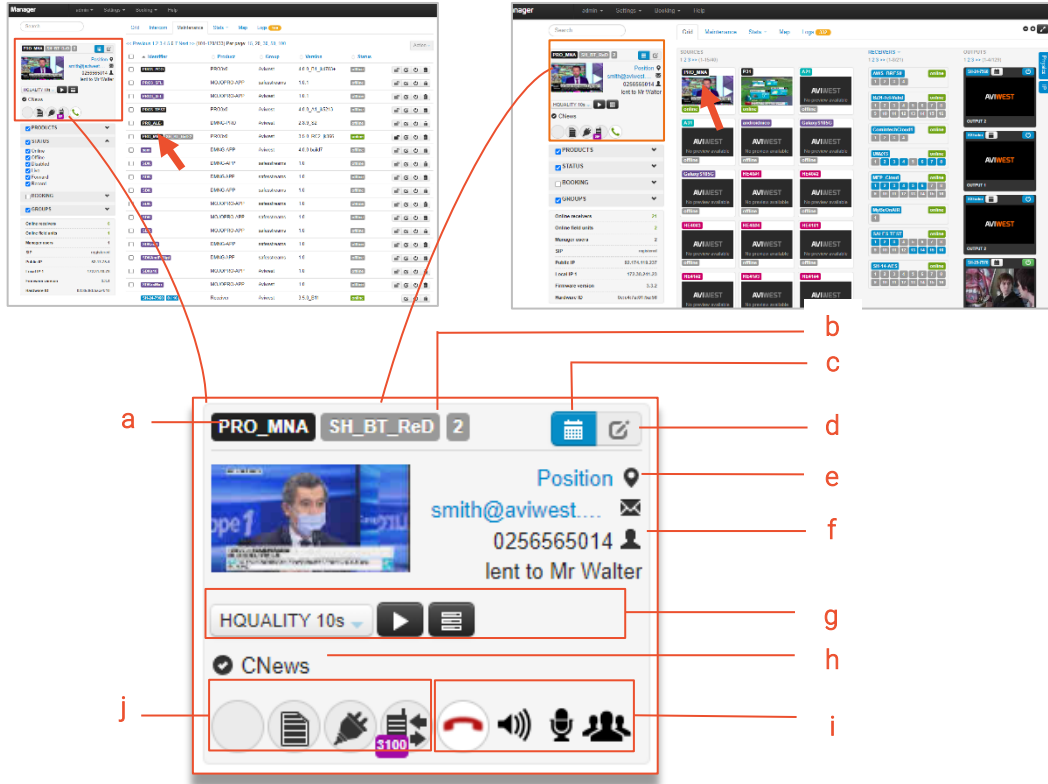



























































































The Field Unit Panel

From the Grid view or Maintenance view, click on the thumbnail or the label to display the field unit panel on the left side of the screen.



The field unit panel provides information about the field unit and gives access to some basic remote control functions:

| | |
|---|--|
| a | Field unit name |
| b | Reservation details Reserved receiver SH_BT_ReD 2 Used Input |
| c | Edit booking button |
| d | Edit group button |
| e | Position (or Last position) to zoom in on the current or last position of the field unit. |
| f | Optional Contact information To enter these details: <ol style="list-style-type: none"> Under the Maintenance tab, search for the field unit. Click on the Settings button (⚙). Fill in the fields as you need (Email, Phone, Optional additional information). Click on Save. |

| g | <p>Remote control buttons</p> <ul style="list-style-type: none"> • a drop down list to allow selecting a Live Profile • Start Live button  • Stop Live button  • Forward button  (DMNG PRO only) • Remote button  that gives access to the user interface of the field unit • Web configurator button  giving access to the Web Configurator (DMNG PRO only) • Network button  that giving access to the network information (DMNG PRO only) | | | | | | | | | | | | | | | | | | | | | | | | | | | | | | | | | | | | | | | | | | | | | | | | | | | | | | | | | | | | | | | | | | |
|---|--|---|--------------|---|--|---|---|---|---|---|--|---|--|--|---|--|--------------|------|--------|--|---|---------------|--|---|-------------|--|---|----------------------|--|---|-----|--|---|-----|--|---|-----------------------|--|---|-----------------------|--|---|----------|----------------------|------|--------|--|---|-----------------------------|--|---|-------|--|---|-----|--|---|-----|--|---|-----|--|---|-----|--|---|------|
| h | <p>Field unit status</p> <table border="1"> <tr> <td></td> <td>Device ready</td> </tr> <tr> <td></td> <td>Checking video, connection in progress or bandwidth test in progress</td> </tr> <tr> <td></td> <td>Live in progress (duration of the transmission)</td> </tr> <tr> <td></td> <td>Record in progress (duration of the recording)</td> </tr> <tr> <td></td> <td>Forward in progress (duration of the transmission)</td> </tr> <tr> <td></td> <td>Data bridge mode enabled on the field unit</td> </tr> </table> |  | Device ready |  | Checking video, connection in progress or bandwidth test in progress |  | Live in progress (duration of the transmission) |  | Record in progress (duration of the recording) |  | Forward in progress (duration of the transmission) |  | Data bridge mode enabled on the field unit | | | | | | | | | | | | | | | | | | | | | | | | | | | | | | | | | | | | | | | | | | | | | | | | | | | | | | |
|  | Device ready | | | | | | | | | | | | | | | | | | | | | | | | | | | | | | | | | | | | | | | | | | | | | | | | | | | | | | | | | | | | | | | | | | |
|  | Checking video, connection in progress or bandwidth test in progress | | | | | | | | | | | | | | | | | | | | | | | | | | | | | | | | | | | | | | | | | | | | | | | | | | | | | | | | | | | | | | | | | | |
|  | Live in progress (duration of the transmission) | | | | | | | | | | | | | | | | | | | | | | | | | | | | | | | | | | | | | | | | | | | | | | | | | | | | | | | | | | | | | | | | | | |
|  | Record in progress (duration of the recording) | | | | | | | | | | | | | | | | | | | | | | | | | | | | | | | | | | | | | | | | | | | | | | | | | | | | | | | | | | | | | | | | | | |
|  | Forward in progress (duration of the transmission) | | | | | | | | | | | | | | | | | | | | | | | | | | | | | | | | | | | | | | | | | | | | | | | | | | | | | | | | | | | | | | | | | | |
|  | Data bridge mode enabled on the field unit | | | | | | | | | | | | | | | | | | | | | | | | | | | | | | | | | | | | | | | | | | | | | | | | | | | | | | | | | | | | | | | | | | |
| i | <p>SIP intercom action buttons</p> <table border="1"> <tr> <td></td> <td>Call button</td> </tr> <tr> <td></td> <td>Hang up button</td> </tr> <tr> <td></td> <td>Mute / Unmute speakers button</td> </tr> <tr> <td></td> <td>Mute / Unmute microphone button</td> </tr> <tr> <td></td> <td>Public / Private conference button</td> </tr> </table> |  | Call button |  | Hang up button |  | Mute / Unmute speakers button |  | Mute / Unmute microphone button |  | Public / Private conference button | | | | | | | | | | | | | | | | | | | | | | | | | | | | | | | | | | | | | | | | | | | | | | | | | | | | | | | | |
|  | Call button | | | | | | | | | | | | | | | | | | | | | | | | | | | | | | | | | | | | | | | | | | | | | | | | | | | | | | | | | | | | | | | | | | |
|  | Hang up button | | | | | | | | | | | | | | | | | | | | | | | | | | | | | | | | | | | | | | | | | | | | | | | | | | | | | | | | | | | | | | | | | | |
|  | Mute / Unmute speakers button | | | | | | | | | | | | | | | | | | | | | | | | | | | | | | | | | | | | | | | | | | | | | | | | | | | | | | | | | | | | | | | | | | |
|  | Mute / Unmute microphone button | | | | | | | | | | | | | | | | | | | | | | | | | | | | | | | | | | | | | | | | | | | | | | | | | | | | | | | | | | | | | | | | | | |
|  | Public / Private conference button | | | | | | | | | | | | | | | | | | | | | | | | | | | | | | | | | | | | | | | | | | | | | | | | | | | | | | | | | | | | | | | | | | |
| j | <p>Indicators giving information about power supply, mass storage devices and intercom.</p> <table border="1"> <thead> <tr> <th style="text-align: left;">Intercom</th> <th>Icon</th> <th>Status</th> </tr> </thead> <tbody> <tr> <td></td> <td></td> <td>Intercom enabled</td> </tr> <tr> <td></td> <td></td> <td>Intercom error</td> </tr> <tr> <td></td> <td></td> <td>SIP Intercom</td> </tr> <tr> <td></td> <td></td> <td>SIP Intercom running (within a Conference)</td> </tr> </tbody> </table> <table border="1"> <thead> <tr> <th style="text-align: left;">Power Supply</th> <th>Icon</th> <th>Status</th> </tr> </thead> <tbody> <tr> <td></td> <td></td> <td>Empty battery</td> </tr> <tr> <td></td> <td></td> <td>Low battery</td> </tr> <tr> <td></td> <td></td> <td>Half charged battery</td> </tr> <tr> <td></td> <td></td> <td>80%</td> </tr> <tr> <td></td> <td></td> <td>90%</td> </tr> <tr> <td></td> <td></td> <td>Fully charged battery</td> </tr> <tr> <td></td> <td></td> <td>External power supply</td> </tr> <tr> <td></td> <td></td> <td>Charging</td> </tr> </tbody> </table> <table border="1"> <thead> <tr> <th style="text-align: left;">Mass-Storage Devices</th> <th>Icon</th> <th>Status</th> </tr> </thead> <tbody> <tr> <td></td> <td></td> <td>USB key or SD card inserted</td> </tr> <tr> <td></td> <td></td> <td>Empty</td> </tr> <tr> <td></td> <td></td> <td>20%</td> </tr> <tr> <td></td> <td></td> <td>40%</td> </tr> <tr> <td></td> <td></td> <td>60%</td> </tr> <tr> <td></td> <td></td> <td>80%</td> </tr> <tr> <td></td> <td></td> <td>Full</td> </tr> </tbody> </table> | Intercom | Icon | Status | |  | Intercom enabled | |  | Intercom error | |  | SIP Intercom | |  | SIP Intercom running (within a Conference) | Power Supply | Icon | Status | |  | Empty battery | |  | Low battery | |  | Half charged battery | |  | 80% | |  | 90% | |  | Fully charged battery | |  | External power supply | |  | Charging | Mass-Storage Devices | Icon | Status | |  | USB key or SD card inserted | |  | Empty | |  | 20% | |  | 40% | |  | 60% | |  | 80% | |  | Full |
| Intercom | Icon | Status | | | | | | | | | | | | | | | | | | | | | | | | | | | | | | | | | | | | | | | | | | | | | | | | | | | | | | | | | | | | | | | | | |
| |  | Intercom enabled | | | | | | | | | | | | | | | | | | | | | | | | | | | | | | | | | | | | | | | | | | | | | | | | | | | | | | | | | | | | | | | | | |
| |  | Intercom error | | | | | | | | | | | | | | | | | | | | | | | | | | | | | | | | | | | | | | | | | | | | | | | | | | | | | | | | | | | | | | | | | |
| |  | SIP Intercom | | | | | | | | | | | | | | | | | | | | | | | | | | | | | | | | | | | | | | | | | | | | | | | | | | | | | | | | | | | | | | | | | |
| |  | SIP Intercom running (within a Conference) | | | | | | | | | | | | | | | | | | | | | | | | | | | | | | | | | | | | | | | | | | | | | | | | | | | | | | | | | | | | | | | | | |
| Power Supply | Icon | Status | | | | | | | | | | | | | | | | | | | | | | | | | | | | | | | | | | | | | | | | | | | | | | | | | | | | | | | | | | | | | | | | | |
| |  | Empty battery | | | | | | | | | | | | | | | | | | | | | | | | | | | | | | | | | | | | | | | | | | | | | | | | | | | | | | | | | | | | | | | | | |
| |  | Low battery | | | | | | | | | | | | | | | | | | | | | | | | | | | | | | | | | | | | | | | | | | | | | | | | | | | | | | | | | | | | | | | | | |
| |  | Half charged battery | | | | | | | | | | | | | | | | | | | | | | | | | | | | | | | | | | | | | | | | | | | | | | | | | | | | | | | | | | | | | | | | | |
| |  | 80% | | | | | | | | | | | | | | | | | | | | | | | | | | | | | | | | | | | | | | | | | | | | | | | | | | | | | | | | | | | | | | | | | |
| |  | 90% | | | | | | | | | | | | | | | | | | | | | | | | | | | | | | | | | | | | | | | | | | | | | | | | | | | | | | | | | | | | | | | | | |
| |  | Fully charged battery | | | | | | | | | | | | | | | | | | | | | | | | | | | | | | | | | | | | | | | | | | | | | | | | | | | | | | | | | | | | | | | | | |
| |  | External power supply | | | | | | | | | | | | | | | | | | | | | | | | | | | | | | | | | | | | | | | | | | | | | | | | | | | | | | | | | | | | | | | | | |
| |  | Charging | | | | | | | | | | | | | | | | | | | | | | | | | | | | | | | | | | | | | | | | | | | | | | | | | | | | | | | | | | | | | | | | | |
| Mass-Storage Devices | Icon | Status | | | | | | | | | | | | | | | | | | | | | | | | | | | | | | | | | | | | | | | | | | | | | | | | | | | | | | | | | | | | | | | | | |
| |  | USB key or SD card inserted | | | | | | | | | | | | | | | | | | | | | | | | | | | | | | | | | | | | | | | | | | | | | | | | | | | | | | | | | | | | | | | | | |
| |  | Empty | | | | | | | | | | | | | | | | | | | | | | | | | | | | | | | | | | | | | | | | | | | | | | | | | | | | | | | | | | | | | | | | | |
| |  | 20% | | | | | | | | | | | | | | | | | | | | | | | | | | | | | | | | | | | | | | | | | | | | | | | | | | | | | | | | | | | | | | | | | |
| |  | 40% | | | | | | | | | | | | | | | | | | | | | | | | | | | | | | | | | | | | | | | | | | | | | | | | | | | | | | | | | | | | | | | | | |
| |  | 60% | | | | | | | | | | | | | | | | | | | | | | | | | | | | | | | | | | | | | | | | | | | | | | | | | | | | | | | | | | | | | | | | | |
| |  | 80% | | | | | | | | | | | | | | | | | | | | | | | | | | | | | | | | | | | | | | | | | | | | | | | | | | | | | | | | | | | | | | | | | |
| |  | Full | | | | | | | | | | | | | | | | | | | | | | | | | | | | | | | | | | | | | | | | | | | | | | | | | | | | | | | | | | | | | | | | | |

Monitoring the Receivers

The **Maintenance** and **Grid** tabs give 2 different views from which you can monitor the receivers.

The Grid tab

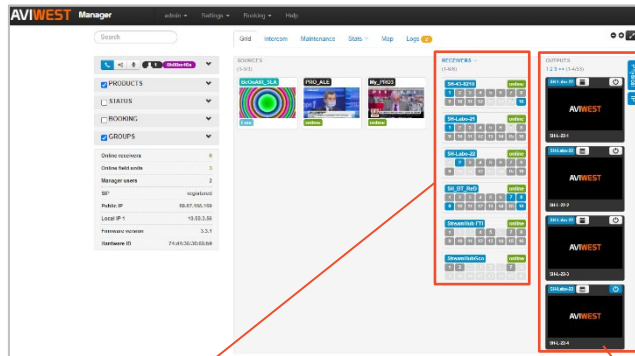



Note:

Receivers are ordered in alphanumeric order to make them easier to find.

Receivers' inputs





You can see the status of the receivers' inputs:

-  Input in use (live or forward action in progress)
-  Input booked for a specific field unit
-  Input available
-  Input not available

This information appears in a tooltip, when placing the mouse over an input number.

Receivers' outputs

The enable/disable button informs about the Output status:

-  Output available
-  Output enabled
-  Operation in progress
-  Error

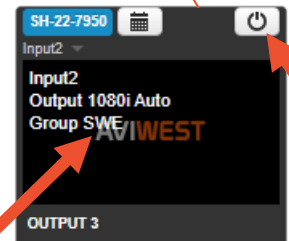

When placing the mouse over it, the output thumbnail gives information:

- Input used
- Output resolution
- Group in which the receiver is

The Maintenance tab

Each line gives details about receivers registered in the Manager.

The screenshot shows the AVIWEST Manager interface with a table of receivers. A red box highlights a receiver entry. Below the screenshot, a horizontal bar displays the details for that receiver: 'SH-27-7990 2 / 10 Receiver ARA 3.5.0 online'. Five numbered arrows point to these details: 1 points to the receiver name, 2 to the input count, 3 to the main group, 4 to the version, and 5 to the status.

| | |
|---|--|
| 1 | Receiver Name |
| 2 | Number of used inputs / number of inputs available |
| 3 | Main group of the receiver |
| 4 | Receiver Version |
| 5 | Receiver Status |

The Receiver Panel

From the **Grid** view or **Maintenance** view, click on a receiver thumbnail or label to display the Receiver Panel on the left side of the screen.

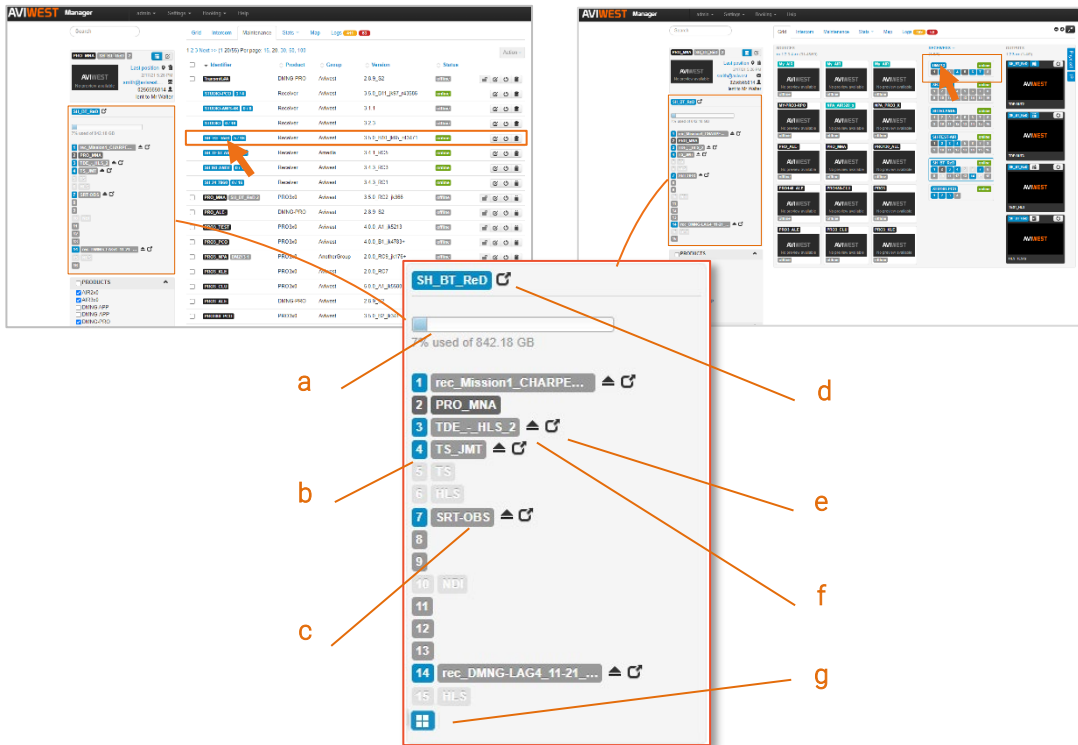

The Receiver Panel provides information about the receiver and the field units connected to it.

- a) Used space on the hard disk drive
- b) Status of the inputs

| | |
|--|--|
| | Input / Multiview in use |
| | SST input reserved for a specific field unit |
| | SST input / Multiview available |
| | Input configured for standard IP protocol |

- c) The associated label can take different colors:

| | |
|--------------|--|
| | Label of the Field Unit for which this input is booked |
| | Live IP input (non-SST) in use, or File Playback in use |
| | IP protocol (non-SST) configured on this input |
| | Field Unit using this input (field unit connected, or Live / Forward in progress) |

- d) Button to access to the receiver webpage.
- e) Button to access directly to the input page on the receiver interface
- f) Button to disconnect the field unit.
- g) Multiview status (when included in the Streamhub license)

Geolocating Field Units

Under the **Map** tab, you can display any online or offline field unit on which the geolocation option is activated and has a valid location.

If several field units are very close, one pin indicates the number of field units.

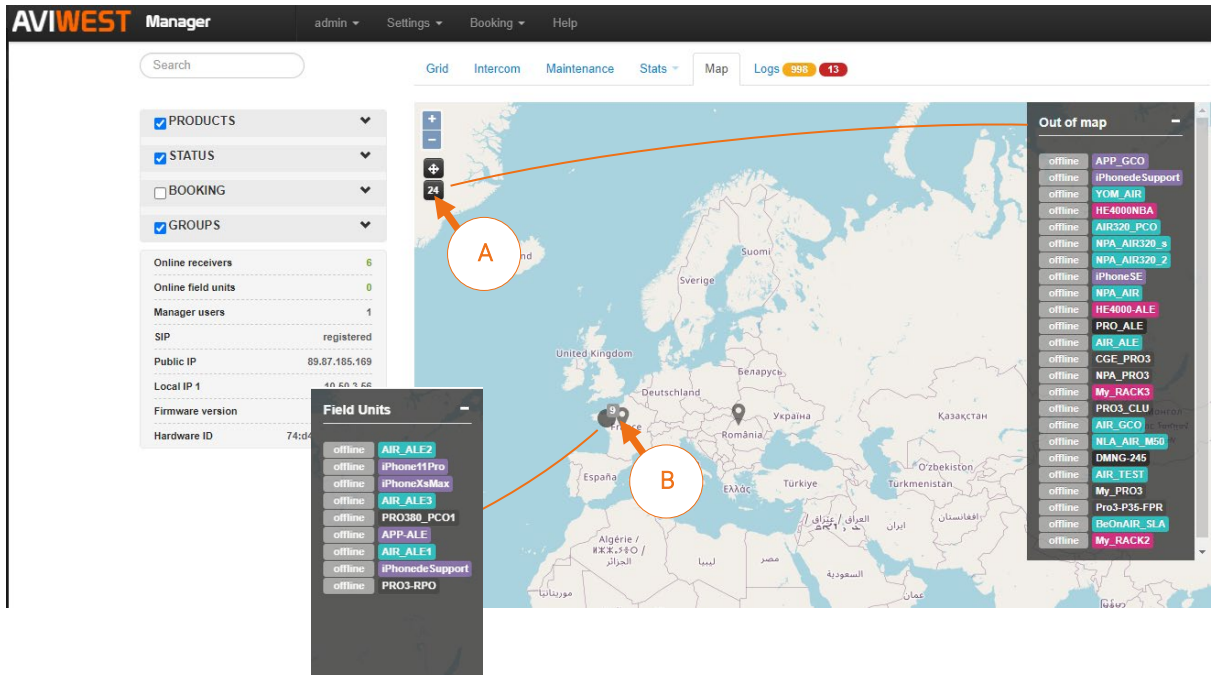

A Number of field units that have not been geolocated.

You can click on the number to list them.

B You can click the pin to show the list of field units present on this location.

For offline field units that have been previously geolocated and on which the geolocation is enabled, the **last position** is kept so that they are still shown on the map, represented by grey pins. If needed, you can click the pin to show the field unit panel and reset the position of a field unit by clicking the 🗑️ button located in the upper right corner of the field unit panel.

Managing Data Usage

Statistics on Field Units and Cellular Data Usage

If the license applied on the Manager allows statistics, the Manager gathers and computes statistics:

- for each SIM card: **Data Used** and **Roaming Used** in kB, MB or GB on the **Stats > SIM Cards** page,
- for each field unit: **Data Used** and **Roaming Used** in kB, MB or GB (i.e. the sum of the **Data Used**, or **Roaming Used**, on each SIM card currently inserted into the field unit) on the **Stats > Field Units** page,
- for each field unit: the cumulative **Live** duration and the cumulative **Forward** duration on the **Stats > Field Units** page.

The Manager can compute the following additional statistics based on the data amount(s) set on the SIM cards (see [Setting the Data Amount on a SIM Card](#)).

- for each SIM card: **Data Used** and **Roaming Used** as a percentage on the **Stats > SIM Cards** page:
 - **Data Used %** = percentage of data used relative to the sum of the amounts **Data Plan** and **Extra Data** set on the SIM card,
 - **Roaming Used %** = percentage of **Roaming Used** relative to the **Roaming Data** set on the SIM card,
- for each field unit: **Data Left** and **Roaming Left** on the **Stats > Field Units** page:
 - **Data Left** = (sum of the amounts **Data Plan** set on the SIM cards + sum of the amounts **Extra Data** set on each SIM card) – sum of the amounts of **Data Used** on each SIM card,
 - **Roaming Left** = sum of the amounts of **Roaming Data** set the SIM cards - sum of the amounts of **Roaming Used** on each SIM card.



Notes:

- To properly compute the **Data Left** and **Roaming Left** on a field unit, the cellular data amount(s) must be set on all the SIM cards inserted into the field unit.
- The Manager gathers statistics on a field unit and on SIM cards from its first connection to the Manager with the Statistics software option enabled, or from the last time the statistics have been reset.
- There are two different methods to reset the cellular data usage on a SIM card: automatic reset (if the type of data set for the SIM card is "Monthly") and manual reset, for more details see [Resetting the Cellular Data Usage](#).
- The daily statistics, on the diagrams and in the daily csv files, include the past 365 days (or the past 30 days on a newly applied license including Statistics).
- The Manager only takes into account the Live and Forward durations when the field unit connects to a receiver through the Manager (not when the field unit directly connects to a receiver).

Setting the Data Amount on a SIM Card

In order to better monitor the cellular data usage on the SIM cards inserted into field units, the administrator, and the users with the "Statistics" permission can set the data amount on each SIM card according to the data plan.

1. Click on **Stats**.
2. Click on **Sim cards**.
3. Click the **IMSI** of a SIM card for which you want to set the amount of data according to the data plan.

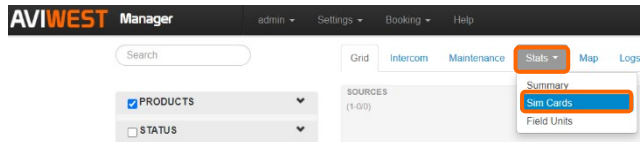

A new window opens.

4. Set the day on which the data plan cycle starts each month (for monthly data only) in the field **Data plan day**.¹
5. Set the data amount in gigabytes (GB) in the field **Data Plan** and select its type (**Monthly** or **Prepaid**).
6. Set the **Extra Data** in gigabytes (GB), if any, and its type (**Monthly** or **Prepaid**).
7. Set the **Roaming Data** in gigabytes (GB), if any, its type (**Monthly** or **Prepaid**).
8. Set the **Phone Number** (optional).
9. Click the **Save** button.

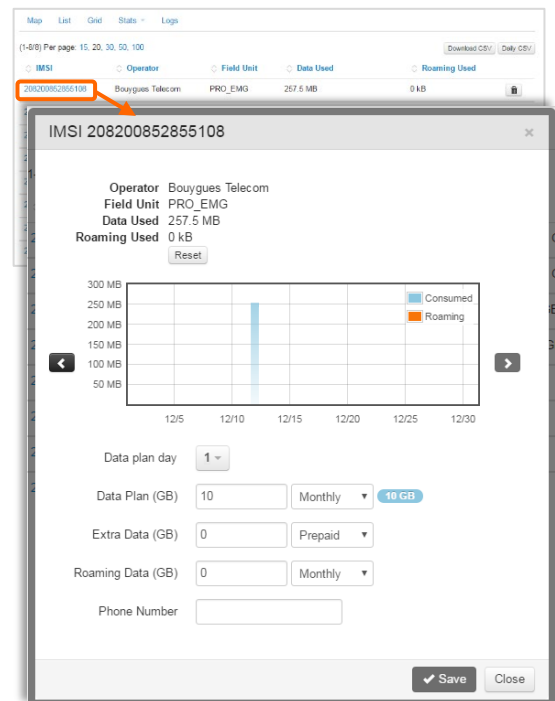

The data usage (**Data Used** and **Roaming Used**) on the SIM card is calculated as a percentage, see [Monitoring the Cellular Data Usage](#).

The Manager can calculate the data left on the field units, see [Monitoring the Use of Field Units](#).

| IMSI | Operator | Field Unit | Data used | Roaming used |
|-----------------|------------------|--------------|-----------|--------------|
| 208103394608122 | SFR | PRO_ALE- | 0 kB | 0 kB |
| 208103695870491 | SFR | AVI_WEST_001 | 0 kB | 0 kB |
| 208201544514928 | Bouygues Telecom | PRO3_JGI | 0 kB | 0 kB |

i Note: the amount of data usage is refreshed only when field units are connected to the Manager. This means that in case of SIM consumption reset according to dataplan, the field unit (including this SIM) amount will be refreshed on next connection to the Manager.

¹ When the type of data is monthly, the data usage is automatically reset on the **Data plan day**.

Monitoring the Use of Field Units

If the license applied on the Manager software enables the statistics, the administrator and the users with the "Statistics" permission can monitor the use of the field units through statistics on the cumulative durations for each type of transmission and on cellular data usage.

1. Click on **Stats**.
2. Click on **Field Units**.

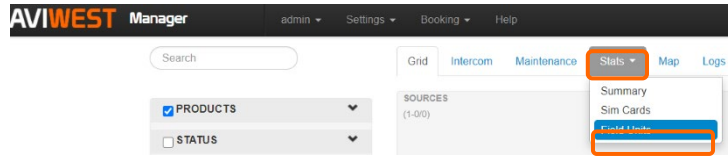

For each field unit, you can see the cumulative duration for each type of transmission, **Live** and **Forward**.

| Identifier | Product | Data used | Data left | Roaming used | Roaming left | Live | Forward |
|------------------|-------------|-----------|-----------|--------------|--------------|-----------|----------|
| AIR_ALE | AIR2x0 | --- | --- | --- | --- | 0h00m00s | 0h00m00s |
| PRO_ALE | DMNG PRO | --- | --- | --- | --- | 2h23m49s | 0h00m00s |
| PRO3_JGI | PRO3x0 | --- | --- | --- | --- | 0h00m00s | 0h00m00s |
| iPhoneDeSamuel | MOJOPRO APP | --- | --- | --- | --- | 0h00m00s | 0h00m00s |
| LCL_AV_04 | MOJOPRO APP | --- | --- | --- | --- | 0h11m02s | 0h55m59s |
| Core | MOJOPRO APP | --- | --- | --- | --- | 17h17m56s | 0h11m43s |
| LCL_AV_04 | MOJOPRO APP | --- | --- | --- | --- | 0h00m00s | 0h00m00s |
| APPdjd | MOJOPRO APP | --- | --- | --- | --- | 0h00m00s | 0h00m00s |
| DevelopersiPhone | MOJOPRO APP | --- | --- | --- | --- | 0h00m00s | 0h00m00s |
| LCL_AV_04 | MOJOPRO APP | --- | --- | --- | --- | 0h00m25s | 0h00m00s |
| LCL_AV_04 | MOJOPRO APP | --- | --- | --- | --- | 0h00m26s | 0h00m00s |
| AVI_AV_05 | DMNG PRO | 0 kB | --- | 0 kB | --- | 1h21m57s | 0h00m00s |
| PRO380_PCO | PRO3x0 | 787.1 MB | --- | 0 kB | --- | 44h11m52s | 0h00m00s |

3. If required, you can:

- Click on **Download CSV** to download the statistics into a csv file.
- Click on **Daily CSV** to download a csv file including the statistics per day.

In the csv files, the data usage is in kB (kilobytes) and the duration in seconds.

Note: if you have filtered the field units to show on the page using the **Groups** or the **Products** filters on the left², the filtering also apply in the csv files.

4. Click the field unit's name to open a new window showing the duration of each type of transmission per day.

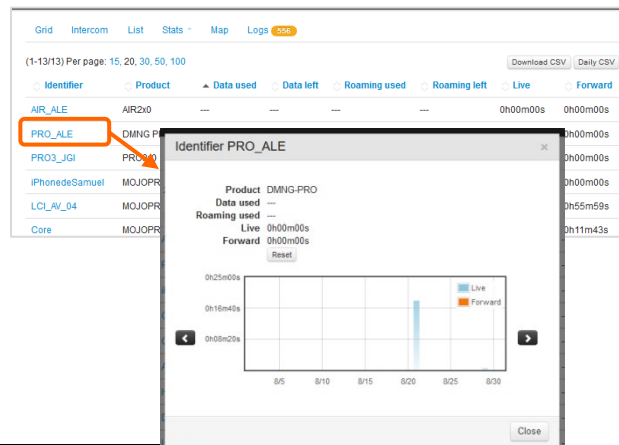

² The **Status** filters do not apply on the **Stats > Field Units** page and in the csv files.

For field units only, you can also see:

- the amount of **Data Used** (roaming excepted) and the amount of **Roaming Used** (in kB, MB or GB) on all the SIM cards inserted into the field unit.
- if the data amount has been set on the SIM cards inserted into the field unit, Manager computes the **Data Left** and the **Roaming Left** on the field unit.

If needed, you can reset the statistics on Live and Forward durations.

Click the field unit's name, click the **Reset** button and then the **Save** button.

The overall durations for each type of transmission are reset.

However, the daily durations are kept in the daily csv file and on the diagram. To reset the cellular data usage on the SIM cards inserted into a field unit, see [Resetting the Cellular Data Usage](#).

Note: the amount of data usage is refreshed only when field units are connected to the Manager. This means that in case of SIM consumption reset according to dataplan, the field unit (including this SIM) amount will be refreshed on next connection to the Manager.

Monitoring the Cellular Data Usage

If the license applied on the Manager software enables the statistics, the administrator and the users with the "Statistics" permission, can monitor the cellular data usage on each SIM card used with field units.

1. Click on **Stats**.
2. Click on **SIM cards**.

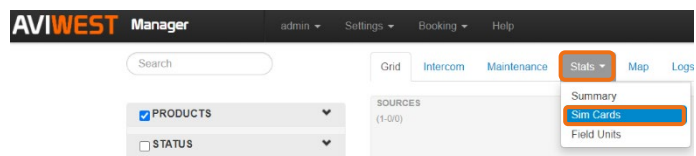

On this page, you can see for each SIM card:

- the **IMSI**,
- the **Operator** of the SIM card (i.e. the cellular carrier),
- the name of the **Field Unit** into which the SIM card is inserted (or into which it was inserted when the name is grey),
- the **Data Used**, roaming excluded, expressed in kilobytes kB, megabytes MB or gigabytes GB,
- the **Roaming Used**, expressed in kilobytes kB, megabytes MB or gigabytes GB,
- if the amount of roaming data has been set for the SIM card, the **Data Used** and **Roaming Used** are also expressed as a percentage.

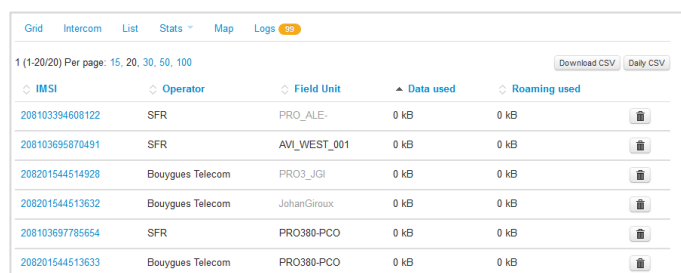
The image shows a screenshot of the SIM cards statistics table in the AVIWEST Manager interface. The table has columns for IMSI, Operator, Field Unit, Data used, and Roaming used. There are 6 rows of data, each with a trash icon on the right. The table is titled '1 (1-20/20) Per page: 15, 20, 30, 50, 100' and has buttons for 'Download CSV' and 'Daily CSV'.

| IMSI | Operator | Field Unit | Data used | Roaming used |
|-----------------|------------------|--------------|-----------|--------------|
| 208103394608122 | SFR | PRO_ALE | 0 kB | 0 kB |
| 208103695870491 | SFR | AVI_WEST_001 | 0 kB | 0 kB |
| 208201544514928 | Bouygues Telecom | PRO3_JGI | 0 kB | 0 kB |
| 208201544513632 | Bouygues Telecom | JohanGiroux | 0 kB | 0 kB |
| 208103697785654 | SFR | PRO380-PCO | 0 kB | 0 kB |
| 208201544513633 | Bouygues Telecom | PRO380-PCO | 0 kB | 0 kB |

You may also want to:

- download the statistics into a csv file: click on **Download CSV**

- download a csv file including the statistics per day click on **Daily CSV**
- **Note:** if you have filtered the SIM cards to show on the page, using the **Groups** filters and/or the **Products** filters on the left³, the filtering also apply in the csv files.
- monitor the daily data usage on a SIM card: click the IMSI of a SIM card to open a new window showing the data usage per day on a diagram.

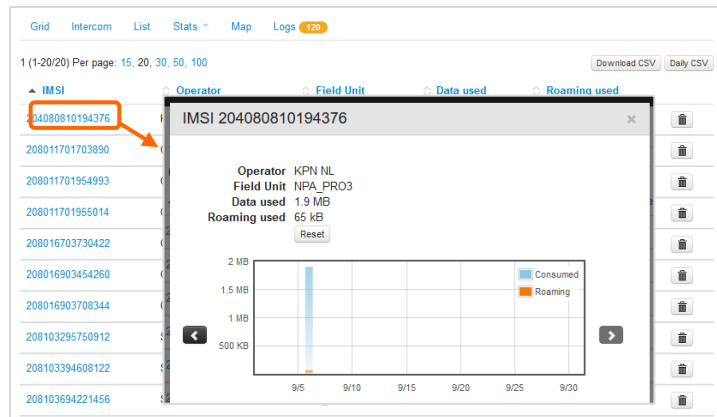

Resetting the Cellular Data Usage

If the license applied on the Manager software enables the statistics, the administrator and the users with the "Statistics" permission can manually reset the data usage on a SIM card.

When the type of data set for the SIM card is monthly, the data usage is automatically reset on the **Data plan day**. However, you can manually reset the data usage on any SIM card, no matters the type of data set for the SIM card.

1. Click on **Stats**.
2. Click on **SIM cards**.
3. Click the **IMSI** of the SIM card on which you want to reset the data usage.
4. Click the **Reset** button.
5. Click the **Save** button.

The screenshot shows the AVIWEST Manager interface. The top navigation bar includes 'Grid', 'Intercom', 'Maintenance', 'Stats', 'Map', and 'Logs'. The 'Stats' menu is open, and the 'SIM Cards' option is selected. Below the navigation bar, there are filters for 'PRODUCTS' and 'STATUS'. The main content area shows a list of SIM cards. The SIM card with IMSI 204080810194376 is highlighted. An arrow points from this IMSI to a detailed view window. This window displays the following information:

- Operator: KPN NL
- Field Unit: NPA_PRO3
- Data used: 1.9 MB
- Roaming used: 65 kB
- A bar chart showing data usage over time (from 9/5 to 9/30). The chart has two series: 'Consumed' (blue bars) and 'Roaming' (orange bars). The y-axis ranges from 500 KB to 2 MB.
- A 'Reset' button is visible below the chart.
- Below the chart, there are input fields for 'Data plan day', 'Data plan (GB)', 'Data plan (Monthly)', 'Extra data (GB)', 'Extra data (Prepaid)', 'Roaming data (GB)', and 'Roaming data (Monthly)'. There is also a 'Phone number' field.
- At the bottom right, there are 'Save' and 'Close' buttons.

The **Data Used**, **Data Left**, **Roaming Used** and **Roaming Left** are reset, however the daily statistics are kept in the daily csv file and on the diagrams.

³ The **Status** filters do not apply on the **Stats > SIM Cards** page and in the csv files.

Deleting a SIM Card

If the license applied on the Manager software enables the statistics, the administrator, and the users with the "Statistics" permission, can delete a SIM card from Manager.

1. Click on **Stats**.
2. Click on **SIM cards**.
3. Click on  on the row corresponding to the SIM card that you want to delete.

Deleting a SIM cards results in deleting the statistics gathered for the SIM card, except the daily statistics, and in updating accordingly the data usage on the field unit stats page (**Data Used, Roaming Used, Data Left** and **Roaming Left**).

Intercom

It is possible to start an audio conference between field unit users and the Manager users.

✓ Make sure that :

- you are connected to the Manager application, using a https address (https://.....) .
- you opened specific ports as indicated in the Installation Guide.
- you connected headphones and you checked audio settings.

Initializing a conference

1. Go to the **Intercom** tab.

2. Click on the conference number.

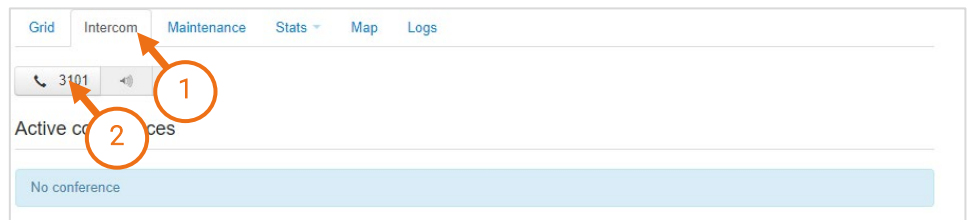

You can hear music on hold.

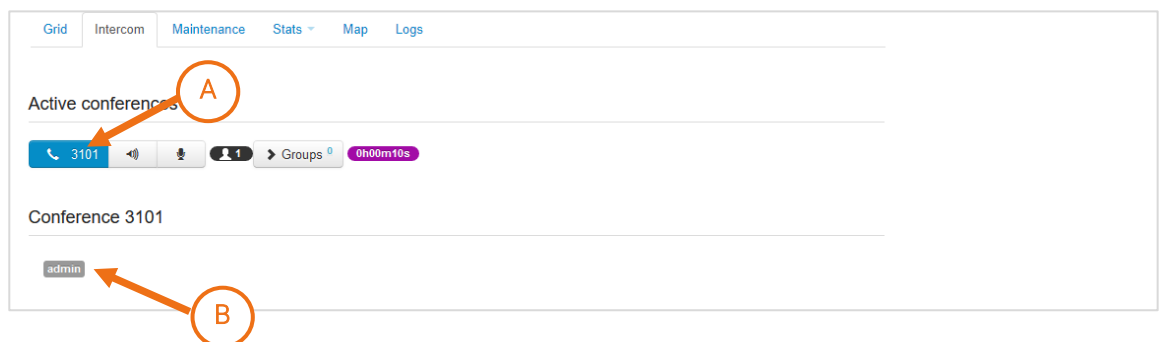

- (A) The initialized conference appears in the Active Conferences section.
(B) Details about the active conference are displayed.

Joining a conference

1. Go to the **Intercom** tab.

2. Under the **Active conferences** section, click the conference number that you want to join.

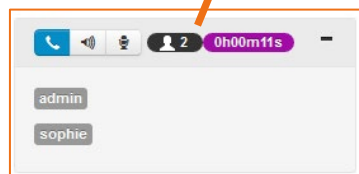
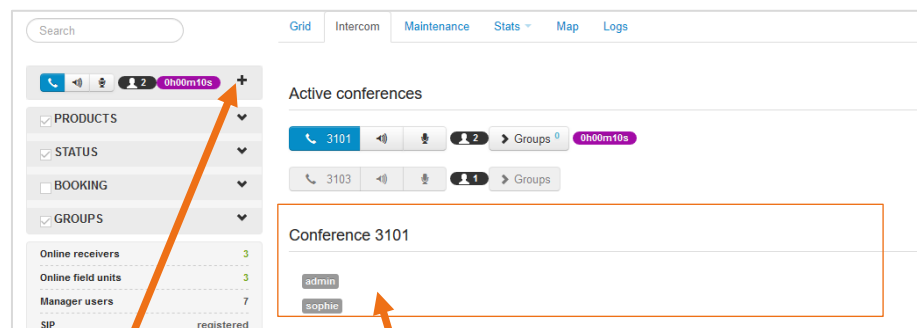
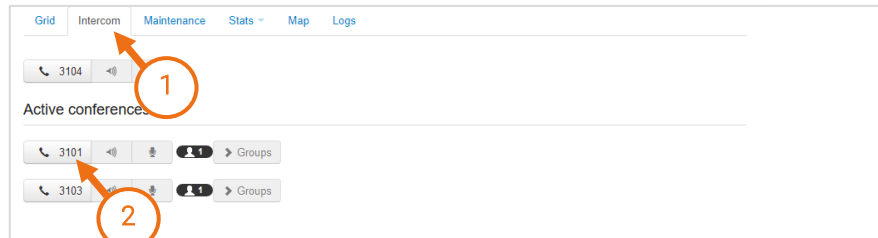

Details about the active conference are displayed.

3. To leave the conference, click on .

Calling a field unit

1. Open the panel of the field unit with which you want to communicate.

2. Click on  to join a conference.



 **Note:** if no conference was initialized, a new conference starts automatically.

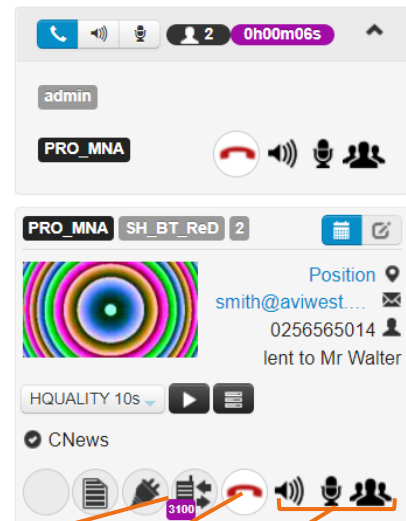

The conference panel appears.



The conference number is indicated.

The icon changed into .

3 additional icons appear.

-  Mute / Unmute speakers
-  Mute / Unmute microphone
-  Private / Public mode

3. To stop the conference, click on .

Calling several field units

1. Under the **Maintenance** tab, click on field units that you want to call.
2. Click on **Action** and **Call** to start the conference.

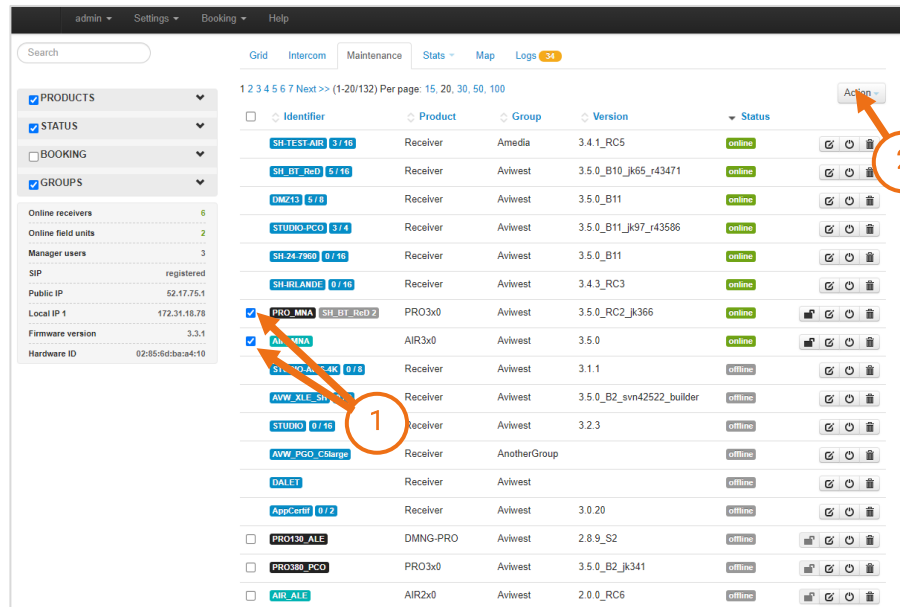



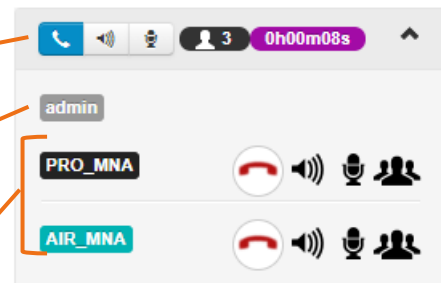

The conference panel opens and indicates the field units that have been called.

Action buttons to stop the conference, mute/unmute speakers, mute/mute microphone.

Name of user(s) connected to the conference.



Each field unit in the conference has an audio bar and can be remotely controlled:

-  Hang up
-  Mute / Unmute speakers
-  Mute / Unmute microphone
-  Private / Public mode

Calling all field units of a group



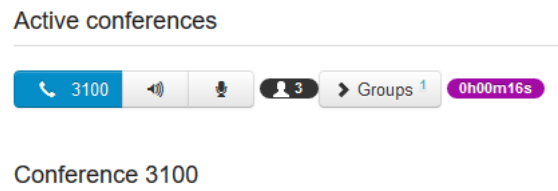
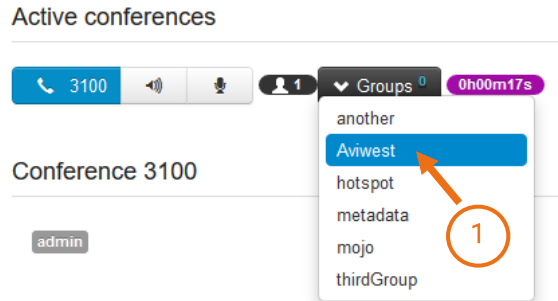

1. Click on the **Intercom** tab.
2. From an active conference, click on the **Groups** button and select the group.

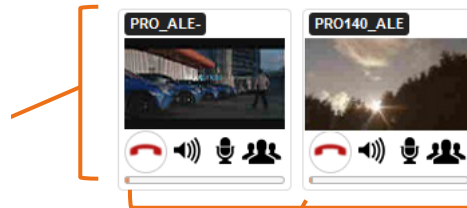

Online field units belonging to the selected group appear.



Each field unit in the conference has an audio bar and can be remotely controlled:

-  Hang up
-  Mute / Unmute speakers
-  Mute / Unmute microphone
-  Private / Public mode

Managing Metadata for Story Centric Workflow

The Manager can be integrated into a story centric workflow that can include PRO, AIR, RACK devices, and MOJOPRO application.

Via an FTP connection, it can ingest .xml or .json files containing data related to missions pushed by NRCS (News Room Computer System) or PAM (Program Asset Management) systems.

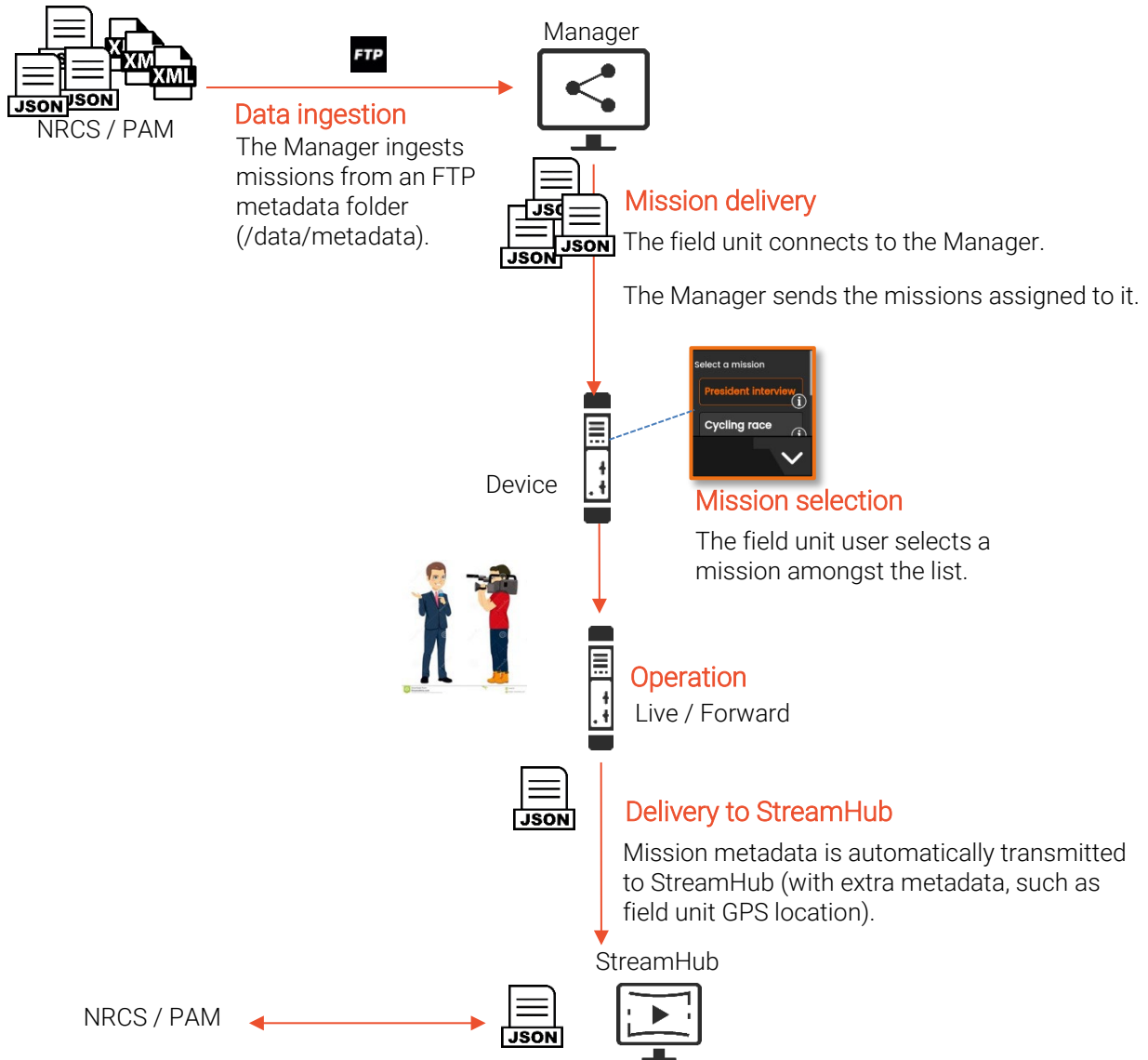

Note:

- When using a Manager Redundancy pool, please make sure that both Master Manager and Backup Manager receive metadata from NRCS and PAM systems.
- To connect to the FTP server please use the “user” login and the password you defined during the server’s installation.
- Please feel free to [contact us](#) for detailed explanation when implementing into your system.

Run-Down or Planning Mode

The management of missions can be done either in a run-down or planning mode.

- Run-down mode :
 - All missions are included within a single xml/json file.
 - Only the most recent file is kept and managed.
- Planning mode :
 - The planning mode allows parsing the input xml file(s) (1 file per mission) by extracting and checking some fields to build a mission object, resulting to a "planning.json" internal file.

Manager analyses each mission for each field unit. Only its missions for the day are submitted.

Note:

Please note that Manager server's time is the reference.

By default, Manager is configured to operate in Run-down mode.

To set a story centric workflow in planning mode:

1. Click on **Settings > General** menu.
2. Select **Planning** mode.
3. Define the deadline time to include the the previous day's missions.

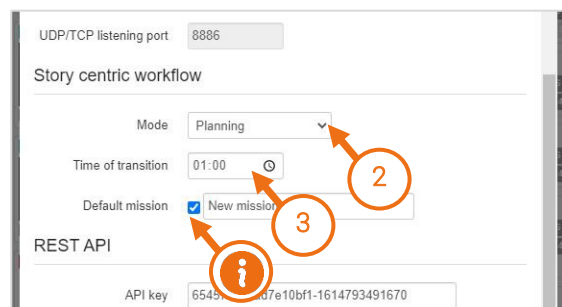

Note:

Enable / disable the possibility to choose an unexpected mission on the field unit.

You can customize the name of this unexpected mission.

XML and JSON File Formats for Run Down Mode

In a Run-Down mode, XML and JSON input files must comply to formats as in the examples below.

In red : mandatory field IDs.

.JSON files

```
"title": [{
  "mission_id": "4570629",
  "device_id": "SNG_ORION",
  "title": "",
  "start_at": "",
  "end_at": "",
  "localization": "",
  "description": ""
}, {
  "mission_id": "4570628",
  "device_id": "PRO3_ALE",
  "title": "mission PRO3_ALE",
  "start_at": "",
  "end_at": "",
  "localization": "",
  "description": ""
}, {
```

.XML files

```
<?xml version="1.0" encoding="ISO-8859-1"?>
<rundown>
  <title>
    <mission_id>4570629</mission_id>
    <device_id>SNG_ORION</device_id>
    <title/>
    <start_at/>
    <end_at/>
    <localization/>
    <description/>
  </title>
  <title>
    <mission_id>4570628</mission_id>
    <device_id>SNG_SIRIUS</device_id>
    <title/>
    <start_at/>
    <end_at/>
    <localization/>
    <description/>
  </title>
</rundown>
```

XML File Format for Planning Mode

In a planning Mode, Manager checks that some values and Ids are available within the .XML configuration file:

- The 'siteName' value is one of the expected values.
- The 'mainStatus' value is one of the expected values.
- The 'startDate' and the 'endDate' of the mission. The Manager will display only the mission when the current date of the Manager is included between these dates, with a tolerance defined by the 'time of transition' setting for the 'endDate'. Missions in the past are automatically removed.
- The 'missionId' is available.
- The 'deviceId' or the 'otherDeviceId(s)' are available.

Reference .XML file

By default, the Manager can parse the following xml template with the default settings (in red):

```
<?xml version="1.0" encoding="UTF-8"?>
<DaletStandardXML timestamp="2022-01-24T15:20:31.742" id="template">
  <Origin>
    <siteName>MyMainSite</siteName><!-- SiteName: Mandatory value ></-->
  </Origin>
  <Titles>
    <Title>
      <mainStatus>valid</mainStatus><!-- MyMissionStatus: (Mandatory value) ></-->
      <name>MyMissionName</name><!-- MyMissionName (Mandatory)></-->
      <assets>
        <StringAssetInfo><!-- Mandatory -->
          <attrName>Mission ID</attrName>
          <attrTagName>missionId</attrTagName><!-- Mandatory tag value -->
          <value>MyMissionId</value><!-- MyMissionId (Mandatory)></-->
        </StringAssetInfo>
        <TimeDateAssetInfo><!-- Mandatory -->
          <attrName>Event Start Date</attrName>
          <attrTagName>startDate</attrTagName><!-- Mandatory tag value -->
          <value>2022-05-11T22:00:00.000</value><!-- MyStartDate (Mandatory)></-->
        </TimeDateAssetInfo>
        <TimeDateAssetInfo><!-- Mandatory -->
          <attrName>Event End Date</attrName>
```

```

<attrTagName>endDate</attrTagName><!-- Mandatory tag value -->
<value>2022-09-30T22:00:00.000</value><!-- MyEndDate -->
</TimeDateAssetInfo>
<StringAssetInfo><!-- Mandatory -->
<attrName>Device ID</attrName>
<attrTagName>deviceId</attrTagName><!-- Mandatory tag value -->
<value>MyDeviceId</value><!-- MyDeviceId -->
</StringAssetInfo>
<TextAssetInfo><!-- Optional but displayed on device -->
<attrName>Description</attrName>
<attrTagName>description</attrTagName><!-- Mandatory tag value -->
<value>My Mission Description</value><!-- My Mission Description -->
</TextAssetInfo>
<TextAssetInfo><!-- Optional -->
<attrName>Location</attrName>
<attrTagName>location</attrTagName><!-- Mandatory tag value -->
<value>MyLocation</value><!-- MyLocation -->
</TextAssetInfo>
<StringAssetInfo><!-- Optional -->
<attrName>Entity</attrName>
<attrTagName>entity</attrTagName><!-- Mandatory tag value -->
<value>MyEntity</value><!-- MyEntity -->
</StringAssetInfo>
</assets>
</Title>
</Titles>
</DaletStandardXML>

```

To get great flexibility, the planning settings are included in a `planningSettings.conf` file.

This is a .JSON file that includes mandatory settings to run properly the Story Centric Workflow in planning mode:

- **siteName_XPath**: XPath expression to retrieve 'siteName' from the XML file.
- **siteName**: array of valid site names the Manager checks. This array should include at least 1 element.
- **mainStatus_XPath**: XPath expression to extract 'mainStatus' from the XML file.
- **mainStatus**: array of valid site name the Manager checks. This array should include at least 1 element.
- **missionName_XPath**: XPath expression to extract 'missionName' from the XML file.
- **missionId_XPath**: XPath expression to extract 'missionId' from the XML file.
- **missionStart_XPath**: XPath expression to extract the start date of the mission from the XML file.

- **missionEnd_XPath**: XPath expression to extract the end date of the mission from the XML file.
- **device_id_XPath**: XPath expression to extract the main targeted device identifier from the XML file.
- **device_id_others_XPath**: XPath expression to extract the secondary transmitters.
- **maxOtherDevices**: Maximum number of device identifier the Manager attempts to get using the `device_id_others_XPath` expression.

You can customize the .JSON configuration file:

1. Click on **admin**, and on **REST API doc**.

The **Manager RESTful API** interface opens.

2. Under the **1_system** menu, you can use the **GET/metadata/planning/Settings** and **POST/metadata/planning/Settings** functions to adapt the configuration .JSON file.

Managing Server Redundancy

You can set up a manager redundancy pool to ensure a high availability of the Manager service. The aim is to minimize operational impacts in case of an unlikely server failure.

Automatic Manager redundancy requires a Manager redundancy package. Please contact your sales contact for more details.

You need to configure:

- 2 Manager servers (one acting as a Master Manager and one acting as a Backup Manager)
- a third service (Redundancy Arbiter), hosted on a third machine that can be a virtual one

The purpose is to:

- replicate the Master Manager database onto the Backup Manager database.
- automatically detect the Master Manager failure and perform an automatic failover switch to the Backup Manager.
- give a virtual IP to point to the effective running server (Master by default) for end users and field unit connections.

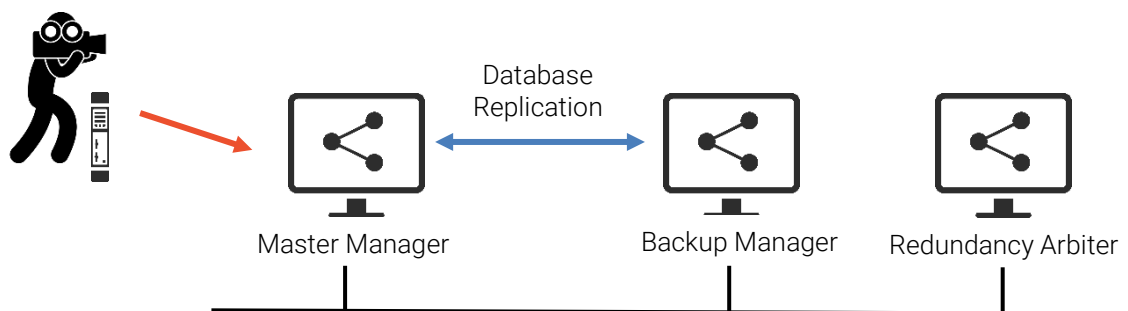

Requirements:

- Master Manager, Backup Manager and Redundancy arbiter are on the same LAN.
- Make sure that a virtual IP address is dedicated to the redundancy pool.

Caution:

Once redundancy is configured, initial data on the Backup Manager are deleted and replaced by the Master manager database.

Configuring redundancy

Glossary:

- **Redundancy pool:**
Set of servers including a Master Manager, a Backup Manager and a Redundancy Arbiter, all using a static IP address within the same LAN.
- **Master Manager:**
The Master Manager is the Manager server that is used for all operations when the system is fully operational (nominal use).
In nominal use, Master Manager has Primary status.
- **Backup Manager:**
The Backup Manager is the server ready to take over operations in case of Master Manager failure within a Manager redundancy pool.
- **Redundancy Arbiter:**
Service running on a third server (could be a virtual host). It participates to the election of the Manager taking Primary status, within the database replica set. It does not host replicated data.
- **Virtual IP address:**
Address managed by Master Manager and Backup Manager and hosted by either Master Manager or Backup Manager, according to the operating state of the redundancy pool.
Please note that this static address must not be included in the dynamic range of the DHCP server. Furthermore, it should not be associated to a MAC address.
- **Primary status:**
Status that gives read-write access to database, authorizes the connection of field units. A Manager with this status hosts the virtual IP address.
- **Online status:**
Status that gives a read-only access to database and that does not allow the connection of field units. With this status, the Manager web user interface is limited to configuration items.

To configure a redundancy, you need to configure IP settings that ensure connection between all servers within the redundancy pool (Master, Backup, and Arbiter).



Before starting configuration, make sure that:

- you saved the database of the Master server.
- the arbiter service is newly installed.

1. Configure IP settings for the Backup Manager:

- a) Connect to the Web interface of the Manager used as a Backup Manager.
- b) In the menu bar, click on **Settings**.
- c) Click on **General**.
- d) Under the Server Redundancy section, select **Backup** running mode.
- e) Enter the IP address of the Master Manager.
- f) Verify the Backup Manager local IP address.
- g) Enter the virtual IP address dedicated to the redundancy pool.
- h) Click on **Save**.

The Backup Manager reboots and is put on hold while the Master Manager is being configured.

The screenshot shows the 'General' settings page. The 'Server redundancy' section is expanded, showing the following fields:

- Server running mode: Backup (selected)
- Master Manager IP: Enter the LAN IP address
- Backup Manager IP: 172.31.1.134
- Manager virtual IP: Enter the virtual IP address

The 'Save' button is highlighted with an orange circle labeled 'h'. Other orange circles labeled 'd', 'e', 'f', and 'g' point to the 'Server running mode' dropdown, the 'Master Manager IP' field, the 'Backup Manager IP' field, and the 'Manager virtual IP' field respectively.



Note:

Should the Master Manager be not configured within 10 minutes, the Backup Manager restarts as a standalone Manager.

2. Configure IP settings for the Master Manager:

- Connect to the Web interface of the Manager used as the Master server.
- In the menu bar, click on **Settings**.
- Click on **General**.
- Under the Server Redundancy section, select **Master** running mode.
- Verify the **Master Manager** local IP address.
- Enter the IP address of the **Backup Manager**.
- Enter the **virtual IP** address dedicated to redundancy.
- Enter the IP address of the **Redundancy Arbiter**.
- Click on **Save**.

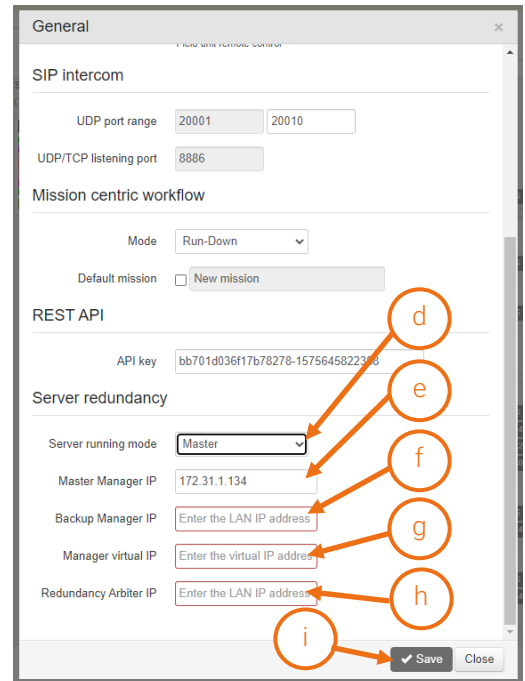

The Master Manager reboots.

Once all servers are configured the user interface is modified:

- A** - The **About** Section indicates the server running mode (Backup or Master).
- B** - Note that the Backup Manager user interface is lightened. Only Logs page, General settings, and a light admin menu are accessible.
- C** - Moving the mouse over the icon displays the status of servers.

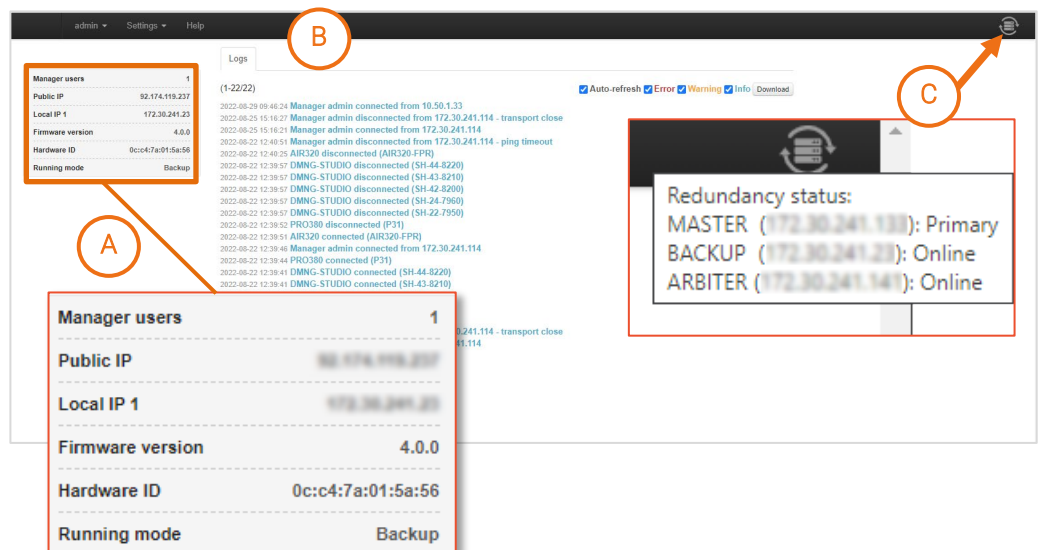

Note:



- The initial IP settings of various Manager servers are explained in the Installation Guide.
- The Backup Manager and the Redundancy arbiter are being configured. Please note that during configuration, servers' web interfaces cannot be accessed. Should the configuration be not effective within 10 minutes, the Master Manager restarts as a standalone Manager.

- From Field Unit interfaces, you need to set destination profiles for a connection to the virtual IP address that you dedicated to redundancy:
 - Make sure that you selected "Manager" as destination profiles types.
 - As the Host IP address, enter the virtual IP address dedicated to redundancy.
 - It is advised to enable the autoconnection option to ensure that field units reconnect automatically in case of Master Manager or Backup Manager failure.

Monitoring redundancy

On the upper right corner of the screen, the icon  appears once the redundancy pool has been configured.

The icon may take different colors to indicate degraded state or failure:

|  Degraded state |  Failure |
|--|--|
| <ul style="list-style-type: none"> • One server is unreachable. • Manager operations are still possible. | <ul style="list-style-type: none"> • 2 servers are unreachable. • Manager operations are no more possible. |

Moving the mouse over the icon displays the status of servers:

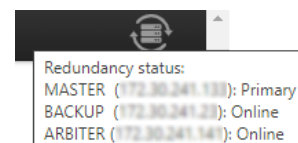

| | Displayed Status | Meaning |
|--------------------|------------------|--|
| Master Manager | Primary | Nominal status |
| | Online | Status indicating that communication is impossible with both Backup Manager and Redundancy Arbiter. Manager operations are not possible. |
| | Unreachable | Connection problem or Manager not operational |
| Backup Manager | Online | Nominal status |
| | Primary | Acts as a Master Manager as long as the initial Master Manager is unreachable |
| | Unreachable | Connection problem or Manager not operational |
| Redundancy Arbiter | Online | Nominal status |
| | Unreachable | Connection problem or Arbiter not operational |

The following diagrams illustrate possible cases:

All servers in nominal status

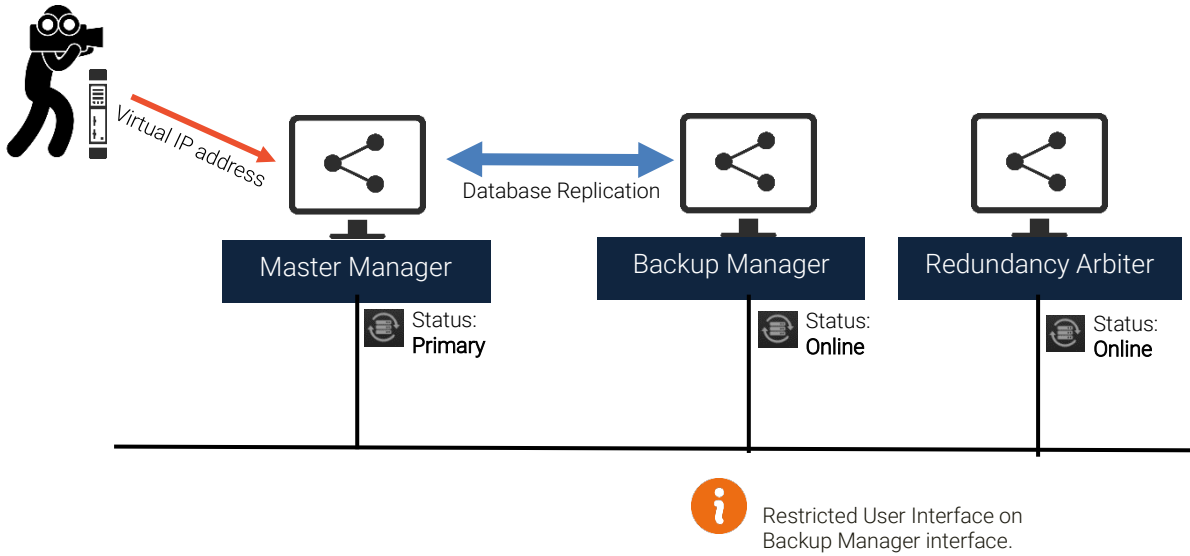

Failure on Backup Manager

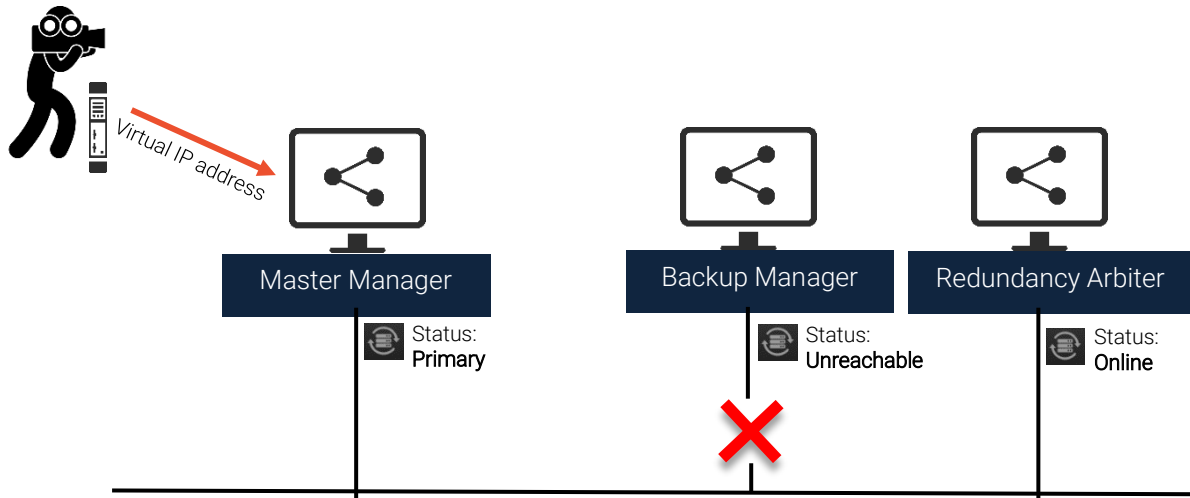

i The Master Manager is fully operational.

Backup Manager has Primary status as long as Master Manager is not operational

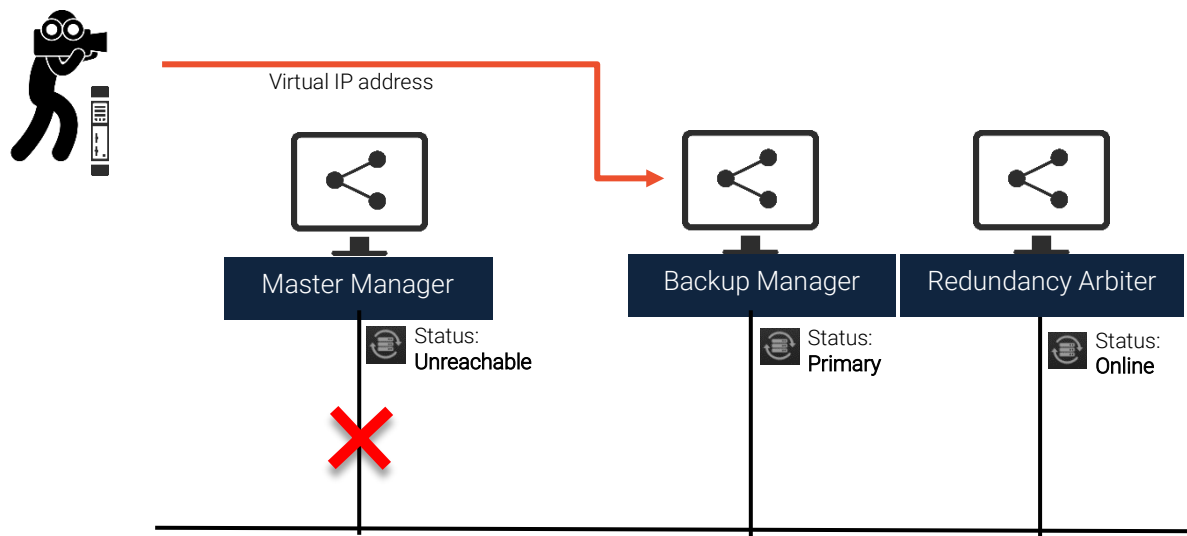

- The Backup Manager has read-write access to the database, and a full user interface.
- Field Units are disconnected from Master server.
- When the Autoconnect mode is enabled on field units, field units reconnect to the Backup Manager automatically. If not, field units must be reconnected manually.

Failure on both Backup Manager and Redundancy Arbiter

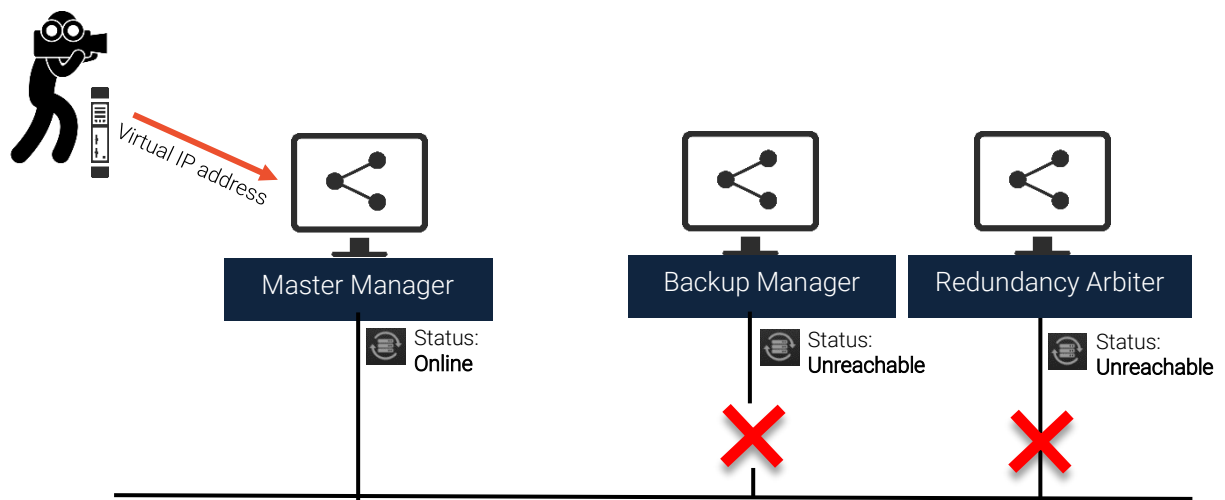

- The Master Manager database is in read-only mode.
- Field units cannot connect to servers.
- Intercom is not available.
- The user interface is lightened.

Maintaining the Manager

Only the administrator can access the **admin** menu to perform software maintenance operations on Manager.

Restarting

To restart Manager:

1. In the menu bar, click on **admin**.
2. Click on **Restart Manager**.
A message prompts you to confirm.
3. Click on **Yes** to confirm.
The Manager restarts.

 **Note:** Restarting the Manager disconnects all the online field units and may stop the action(s) in progress on the field units (Live or Forward) and on the Manager's outputs.

Updating

 **Note:** Updating the Manager software disconnects all the online field units from the Manager and may stop the action(s) in progress on the field units (Live or Forward) and on the Manager's outputs.

To update the Manager software:

1. Download the new Manager software on the computer you are using to access the Manager web interface.
2. In the menu bar, click on **admin**.
3. Click on **Update Manager**.
A new window prompts you to browse the computer in order to select the ".fw" software version.
4. Click the **Browse** button.
5. Browse your computer to select the software version.
6. Click the **Update** button.
The Manager restarts after the update.

Exporting the Connection Profile

You can export the Manager profile to allow the connection to a MOJOPRO interface.

1. In the menu bar, click on **admin**.
2. In the **Export** section, click on **Connection Profile**.
3. Enter the Manager public IP address.
4. Select the **Group** in which MOJOPRO interface must be included.
5. Click on **Download**.
6. Save the .awc file to be imported into MOJOPRO interface.

Exporting the Database

Before performing significant changes in the ecosystem, the administrator may save the database, which includes the configuration of the ecosystem (groups, users, registered products, priorities and reservations, statistics...), as well as the settings of the Manager software (connection and authentication settings).

1. In the menu bar, click on **admin**.
2. Click on **Export database**.
3. The Manager database is saved as an .awj file. This file is encrypted and cannot be read.

Importing the Database

If required, the administrator can import a database onto the Manager.

1. In the menu bar, click on **admin**.
2. Click on **Import database**.
3. Click the **Browse** button.
4. Browse your computer and select the .awj file to import.
5. Click the **Open** button.
6. Click the **Apply** button.

The database is imported onto the Manager.

Account Locking Policy

If the maximum number of authentication failures exceeds the configured threshold, the access to the interface is denied. However, it does not log out the Administrator and User(s) who are already logged in to.

You can disable this locking policy or modify the number of attempts before locking the account.

1. Log in as **Admin**.
2. In the menu bar, click on **Settings** and select **General**.

Untick the **Accounts locking** box to disable the locking function.

Modify the value to change the number of attempts authorized to log in before the account is locked.

Unlocking the Web Page

If a user has entered too many wrong consecutive passwords, logging to the web page is blocked to any new user.

To unlock the web page:

1. Log in as **Admin**.
2. In the menu bar, click on **Settings** and select **General**.
3. Click the **Unlock Accounts** button.

The Web page is accessible to users.

 **Note:** if the web page was blocked when trying to log in as the Administrator, you must unlock the Web page via the Server's Settings Menu (refer to the **Configuration and Advanced Guide**).

Troubleshooting

This section may help you solve some issues.

Viewing the Logs

The **Logs** page lists information, error and warning messages. By default, the page is automatically refreshed as soon as a new event occurs.

From the **Logs** page you can

- untick the **Auto-refresh** checkbox so that the **Logs** page is no longer refreshed with new events. If so, the new events are no longer shown until ticking the checkbox again, then the page is refreshed with the events which could have occurred and the new events.
- filter events according to their type using the checkboxes located on the top of the page.
- download the logs.

The **Logs** page is cleared after restarting the Manager software and after rebooting the server. However, the downloadable log file always includes the events occurred over the past 7 days.

Getting a Report File

AVIWEST's support team often asks for a report file in order to investigate the issues you may face. Only the administrator can get a report file.

1. Click on **admin**.
2. Click on **Get report**.

A message prompts you when the report is ready.

3. Click on **Download** to download the file on your computer.

You can now send the report file by email to AVIWEST's support team along with the description of the issue you have faced as well as the date and time when it occurred.

Connection Errors

When a field unit tries to connect to the Manager software or when it tries to start a Live or a Forward, the following error messages may appear in the upper right corner of the page of the Manager (and sometimes on the **Logs** page and in the field unit panel).

| Message | Meaning / Solution |
|--|--|
| A field unit cannot connect to the Manager | |
| Field Unit message: Connection to server failed Or Authentication Failed | <p>The field unit can no longer connect to the Manager. There are two potential solutions:</p> <ul style="list-style-type: none"> The username and password set in the Manager profile configured on the field unit are incorrect: edit the Manager profile on the field unit to set the username and password of a group of the Manager. To check the username and password of a group, see and clicking on Save. If the AES is activated on the field unit and on the Manager, check that the passphrase set on the field unit is correct (please refer to the dedicated guide). |
| The Manager cannot connect a field unit to a receiver's input | |
| No receiver registered | Register at least one receiver to the Manager. |
| No online receiver | Enable at least one receiver or check the receiver connection. |
| As no booking is found, Live on [field unit identifier] ([Product name]) requires at least one receiver within the group [name]. | Configure at least one receiver in the same group as the field unit. |
| Forward action on [field unit identifier] ([Product name]) requires at least one receiver within the group [name]. | Configure at least one receiver in the same group as the field unit. |
| No free input for [action] on [field unit identifier] ([Product name]) within the group [name]. | All the inputs belonging to the group are already online, reserved for live transmissions coming from other field units. |
| Invalid input linked to the locked output for [field unit identifier] ([Product name]). | <p>The receiver's output is locked on an input. The Manager can't change this output setting as the receiver version is anterior to 3.3.3.</p> |
| Input reserved for [field unit identifier] (Product name) is busy. | <p>The input reserved for the live transmissions coming from this field unit is busy (another field unit is connected to the input—direct connection between the field unit and the receiver-). There are two potential solutions:</p> <ul style="list-style-type: none"> disconnect the field unit connected to the reserved input, cancel the reservation for this field unit (and reserve another output for this field unit). |
| Receiver of input reserved for [field unit identifier] (Field Unit's Product Name) is disabled. | <p>The receiver to which belongs the reserved input for the live transmissions coming from this field unit is disabled. There are two potential solutions:</p> <ul style="list-style-type: none"> enable the receiver (from the Maintenance tab of the Manager), cancel the reservation for this field unit (and reserve an output of another receiver for this field unit). |
| Receiver of input reserved for [field unit identifier] (Field Unit's Product Name) is offline. | <p>The receiver to which belongs the reserved input for the live transmissions coming from this field unit is offline. There are two potential solutions:</p> <ul style="list-style-type: none"> verify the receiver connection settings cancel the reservation for this field unit (and reserve an output of another receiver for this field unit). |
| Input not available for [field unit identifier] | No input available on this receiver. |

Contact Us

Should you have any question or require complementary information, feel free to visit www.aviwest.com or contact AVIWEST's technical support team:

Global Headquarters

Parc Edonia, Bat. X1
Rue de la Terre de Feu
35760 SAINT-GREGOIRE Cedex
FRANCE

Mail: support@aviwest.com
Phone: +33 (0) 2 56 56 50 18

LatAm Office

Oficina n°504, Calle Barros Borgono N°160
comuna de Providencia, ciudad de Santiago au CHILI

APAC Office

Unit 505A, 5/F, Block A
Sea View Estate
2-8 Watson Road, North Point, HONG KONG

Indian Office

Netaji Subhash Chandra Place
KLJ towers
NEW DEHLI

US Office

60 Braod St, Ste 3502
10004 New York, NY

Dubai Office

Dubai Silicon Oasis, HG Building
Office 306 Dubai, UAE